

**SUBCOURSE
OD1747**

**EDITION
A**

**REFRIGERATION AND
AIR CONDITIONING I**

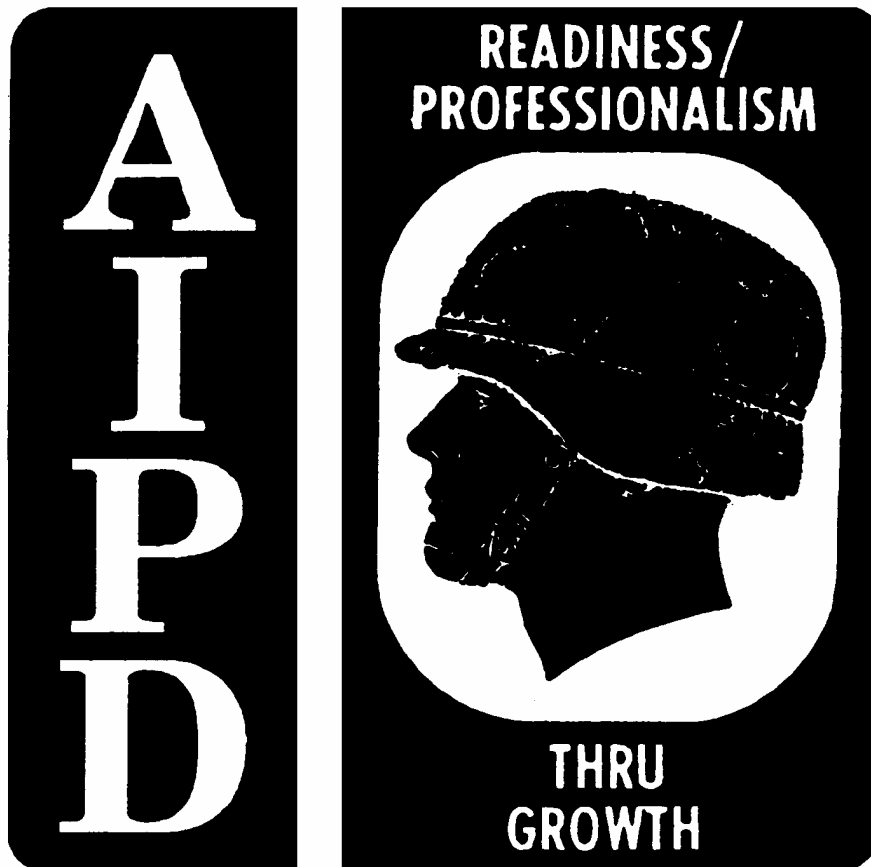

**THE ARMY INSTITUTE FOR PROFESSIONAL DEVELOPMENT
ARMY CORRESPONDENCE COURSE PROGRAM**

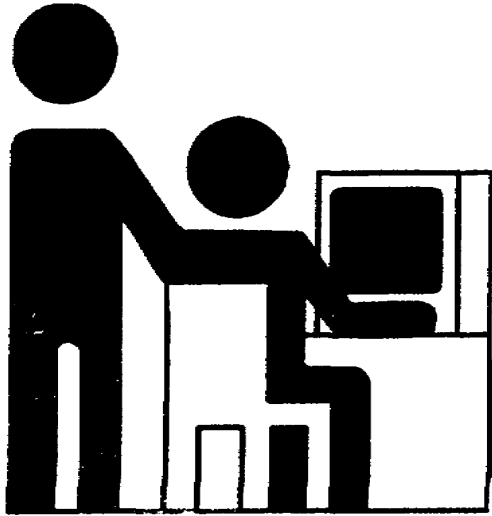

Notice to Students

Use the Ordnance Training Division website,
<http://www.cascom.army.mil/ordnance/>,
to submit your questions, comments, and suggestions
regarding Ordnance and Missile & Munitions
subcourse content.

If you have access to a computer with Internet capability and can receive e-mail, we recommend that you use this means to communicate with our subject matter experts. Even if you're not able to receive e-mail, we encourage you to submit content inquiries electronically. Simply include a commercial or DSN phone number and/or address on the form provided. Also, be sure to check the Frequently Asked Questions file at the site before posting your inquiry.

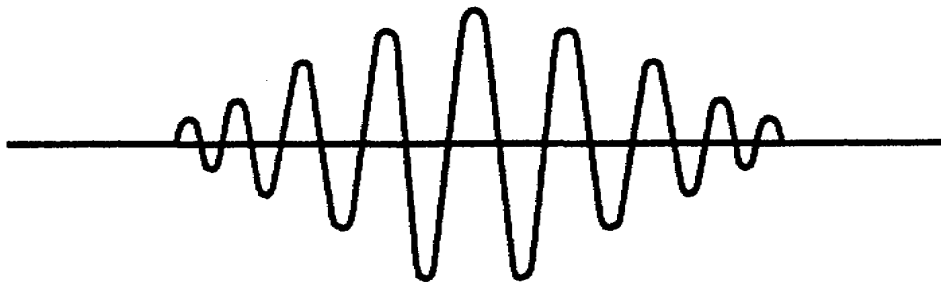

REFRIGERATION AND AIR CONDITIONING I
(Fundamentals)

Subcourse OD1747

Edition A

United States Army Combined Arms Support Command
Fort Lee, VA 23801-1809

10 Credit Hours

INTRODUCTION

This subcourse is the first of four subcourses devoted to basic instruction in refrigeration and air conditioning.

This subcourse explains the fundamentals of electricity and their application in the refrigeration process. It discusses circuits, motors, and troubleshooting. This is followed by a discussion of fundamentals and the maintenance of the gasoline engine. The theory of refrigeration is also explained based on the characteristics of refrigerants.

Unless otherwise stated, whenever the masculine gender is used, both men and women are included.

INTRODUCTION

WITHIN THE LAST 20 years refrigeration has become a vital part of American economy. Not only does nearly every household have its own private machine for the manufacture of ice and cold, but the vast industry of transporting, storing, and selling fresh foods would collapse overnight without the facilities to preserve fruits, meats, and vegetables. Furthermore, many amazing therapies of medical science depend upon refrigeration.

All over the world the Army maintains bases equipped with the latest war materiel for keeping the peace or for defending our country. The men who man these bases must have suitable working conditions, proper food, and the best hospital treatment possible. In accomplishing these tasks, the Army makes use of every phase of refrigeration. Consequently, it must have men who will make a career of installing and maintaining the many refrigeration units it owns.

This course is offered to personnel who wish to improve their knowledge of the science of refrigeration. This memorandum explains the fundamental reactions which make up the process of present-day refrigeration. It should help the man who is interested in increasing his knowledge of refrigeration. Review exercises are at the end of each chapter.

ACKNOWLEDGMENT

Grateful acknowledgement is made to Allied Chemical Corporation; E. I. du Pont Nemours and Company, Inc., and the American Society of Heating, Refrigeration, and Air Conditioning Engineers for permission to use illustrations from their publications.

CONTENTS

Page

Introduction.....i

Acknowledgementii

Chapter

1 Principles of Electricity1

2 Fundamentals of Gasoline Engines.....41

3 Physics of Refrigeration48

4 Refrigerants58

Glossary63

Appendix.....66

Answer to Review Exercises77

Principles of Electricity

We all use electrical equipment, such as lights, radio, television, electric stove and heaters, refrigerators, air conditioners and many more. We use these items many times a day and accept them as a matter of course. As long as the electrical equipment operates properly, we accept it with little concern about what actually takes place. Each of these devices operates because electric current flows through it.

2. To understand how electricity functions, you need to know the theory of electricity. The word "electric" is derived from the Greek word meaning "amber." The ancient Greeks used the word describe the strange force of attraction and repulsion that was exhibited by amber after it had been rubbed with a cloth. By knowing what electricity does, people have long ago developed theories which now are proving productive.

3. After centuries of experimentation by the world's greatest scientists, laws by which electricity operates are becoming more widely known and better understood. Also, the world has arrived at a generally accepted theory of the composition of matter. Therefore you must learn about "matter" and certain magnetic effects exhibited by matter.

1. Electrical Fundamentals

1-1. Matter means all substance - solids, liquids, and gases. Today, the accepted theory is that matter is composed of three long-lived particles and many more short-lived particle. We are concerned only with one of the three long-lived particles - the electrons.

1-2. **Electron Flow.** Where there is a general movement of electrons in one direction, an electric current flows. The electrons together with protons (positively charged particles) and neutrons (neutral particles), make up atoms, of which all substances are composed. The protons and neutrons are in the nucleus (center of atom) and generally do not move about within a

substance. The remainder of the atom is composed of electrons, which are in constant motion about the nucleus.

1-3. Electrons move at a high rate of speed in orbit around the nucleus and carry a negative charge. The electrons apparently do not bunch up as the protons do in the nucleus. An atom may be compared to our planetary system, with the sun as the nucleus and the earth and other planets representing the electrons. This is illustrated in figure 1, which shows the similarity between a hydrogen atom and our earth-sun system. More complex atoms have a larger nucleus and additional electrons. The electrons are considered to be relatively loose and are usually considered to be that which make up an electric current or flow.

1-4. Electricity is often referred to as static electricity or dynamic electricity. A generator is said to produce dynamic electricity, and from this comes the word "dynamo" as another name for a generator. This is a machine which converts mechanical energy to electrical energy. Generally speaking, we are able to control dynamic electricity so that it is a useful force which we can put to work. A battery is also a source of dynamic electricity which we can control. The chemical action in a battery produces electrical energy which has three useful applications in an automobile. It drives the electric motor which starts the engine. It supplies energy to the spark plugs as heat for ignition, and the car lamps also use electrical energy for light. The car's generator recharges the battery and supplies the electric power when the engine is running. Generators and batteries are the most widely used sources of dynamic electricity. Now let's discuss static electricity and its effects.

1-5. The effects of static electricity can be observed in dry weather when you run a comb through your hair. The crackling you hear is the result of small discharges of electricity, and in a dark room you can see the tiny flashes of light a mirror. Lightning in a summer storm is the violent discharge of tremendous static charges.

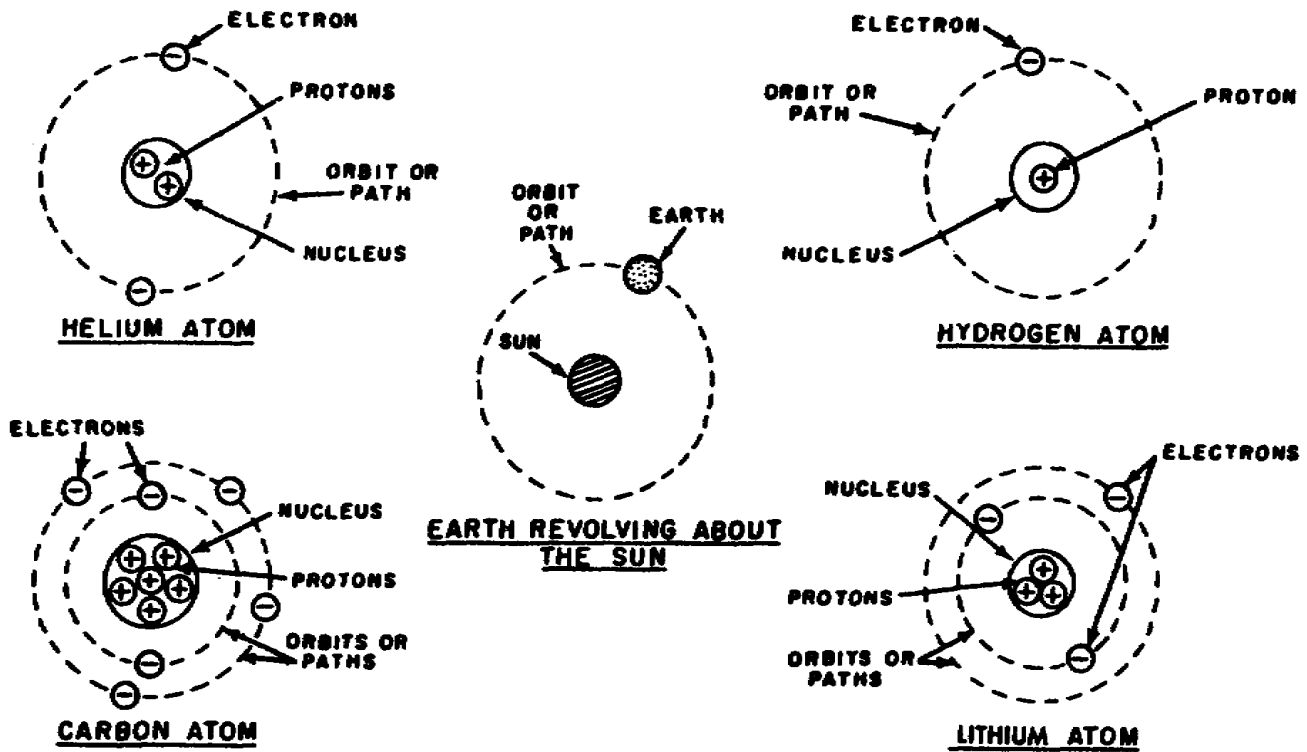

Figure 1. Structure of atoms compared to earth and sun.

A charge accumulates over a period of time, and when it becomes great enough to overcome the resistance of the air, a bolt of lightning occurs. Static electricity is the result of friction which dislodges enough electrons to form a charge. When the charge becomes very great, the accumulated energy is released in the form of electrical energy accomplished by lightning and thunder.

1-6. The next discussion will cover the three most common terms in electricity: "voltage," "current," and "resistance." These three words are probably the most important in electrical fundamentals. If you understand the relationship between voltage, current, and resistance, you will have a good foundation on which to build your knowledge of electricity. Therefore, it is important that you learn the meaning of these terms. Since electricity cannot be seen, we will present visual comparisons to help you in understanding the relationships.

1-7. Voltage is one of the several terms which mean the same thing. These terms are: "voltage," "potential," "electromotive force (emf)," "potential difference," and "electrical pressure." The last term, "electrical pressure," comes close to telling what voltage is. For example, the voltage of a battery is like water pressure in a hose when the nozzle is closed. This is called potential energy, not performing work. When the nozzle is opened, the water is forced out by the pressure, thus doing work. This may be related to closing an electrical switch, such as turning on your automobile lights. The potential energy of your

battery is then released, performing the work of lighting the lights. The voltage is expended in the lights in the form of heat and light. Remember that voltage is electrical pressure.

1-8. The current flow is made possible by closing the switch which lowers the resistance to the voltage. Since this circuit has a relatively high resistance, the lamps could be burned for several hours before the battery would be discharged. The starter for the engine has a very low resistance, so it will draw a large current from the battery. It uses so much energy that the battery may become completely discharged by operating the starter for just a few minutes. This is reasonable because the starter is doing more work (converting electrical energy into mechanical energy) than are the car lights. With the foregoing discussion in mind, let us now consider concise definitions of our electrical terms.

Voltage is electrical pressure.

Current is the movement of electrons.

Resistance is the opposition to current flow.

1-9. Voltage is measured in volts. Current is measured in amperes. Resistance is measured in ohms. One volt is the electrical pressure required to cause 1 ampere of current to flow through a resistance of 1 ohm. Scientists have made experiments which show that 6280 trillion electrons pass a given point each second when there is 1 ampere of current in a circuit.

1-10. Resistance to electric current is present in all matter, but one material may have much more resistance than another. Air, rubber, glass, and porcelain have so much resistance that they are called insulators and are used to confine electricity to its proper circuit. The rubber covering on the wires to an electric lamp prevents the wires from touching each other and causing a short circuit. The rubber also protects a person who is using the lamp so that he does not receive an electric shock. Air acts as an insulator whenever a light switch is opened. Air fills the gap between the open contacts of the switch, and no current flows because of the high resistance. However, even air may act as a conductor if the voltage is

high enough; otherwise, there could not be the electrical discharge which appears in a lightning strobe.

1-11. Metals are good conductors of electricity but some are better than others. Copper and silver are both good conductors of electricity because of their relatively low resistance. Aluminum is not as good, but is used for long overhead spans because of its light weight. Iron is a poor conductor, although it is used in combination with aluminum for added strength. Alloys of nickel and chromium are used in heater element to provide a specific resistance which passes enough current to heat the wires to a red glow. The alloy makes it possible to operate at high temperatures without melting. Copper is

NUMBER ¹	SIZE		WEIGHT (FEET PER POUND)	CURRENT-CARRYING CAPACITY (AMPERES)			RESISTANCE (OHMS PER 1,000 FEET)
	NATURAL SIZE	DIAMETER (INCHES)		RUBBER- INSULATED WIRE IN CONDUIT OR CABLE	RUBBER- INSULATED WIRE ON INSULATORS	WEATHER- PROOF WIRE ON INSULATORS	
40	TOO SMALL TO SHOW ACCURATELY	0031	33,410	---	---	---	---
36		0050	13,210	---	---	---	---
30		0102	3,287	---	---	---	---
24		0201	817.4	---	---	---	---
18		0403	203.4	---	---	---	---
16		0508	127.9	---	---	---	---
14		0640	80.44	15	24	30	2.48
12		0808	50.59	20	31	39	1.56
10		1018	31.82	25	42	54	0.98
8		1284	20.01	35	58	71	0.62
6	184	12.58	50	78	98	0.39	
4	232	7.91	70	105	130	0.24	
2	292	4.97	90	142	176	0.15	
1	332	3.94	100	164	203	0.12	
1/0	373	3.13	125	193	237	0.10	
2/0	419	2.48	150	223	274	0.08	
3/0	470	1.97	175	259	318	0.06	
4/0	528	1.56	225	296	368	0.05	
350 MCM ²		661	0.925	300	421	508	0.03

¹ SIZES 40 TO 8 ARE SOLID WIRES SIZES 6 TO 2 ARE 7-STRAND CABLES SIZES 1 TO 4/0 ARE 19-STRAND CABLES SIZE 350 MCM IS A 37-STRAND CABLE

² MCM IS THE DESIGNATION OF WIRE SIZE IN THOUSANDS OF CIRCULAR MILS 350 MCM = 350,000 CIRCULAR MILS

Figure 2. Copper wire size and resistance.

relatively cheap and a good conductor; it is the most widely used for wiring circuits.

1-12. The resistance of a copper wire is determined by three things: the cross-sectional area, the length, and the temperature. In normal temperature ranges the change in resistance is very small. The main factors of resistance are the area or cross section of a wire and its length. A wire with a larger diameter will have a greater cross-sectional area than will a smaller wire, and consequently less resistance. A long wire will have more resistance than a short one. Figure 2 shows the relationship between wire size and resistance. The first column gives the wire by number. A No. 40 wire is about the diameter of a hair. Sizes larger than No. 4/0 (spoken as four aught) are given in thousands of circular mil (350 MCM is 350,000 circular mils). The column at the right gives the resistance in ohms for 1000 feet of wire. One thousand feet of No. 10 copper wire has a resistance of about 1 ohm. The safe current carrying capacity is given in three columns which show the effects of insulation and conduit on the heat radiation ability of the conductor.

1-13. **Magnet Characteristics.** Magnetism related to electricity as heat is related to light. Whenever light is produced, we have heat; and wherever electricity is produced in the form of an electric current, we have magnetism. However, heat can be made without visible light and magnetism can be detected without an electric current. The effects of magnetism make a good starting place toward an understanding of electricity. Many of the fundamental laws can be demonstrated by simple experiments which you can perform for yourself.

1-14. A magnetic compass needle, a bar magnet, and some iron filings are the main things required. The compass needle will point toward the magnetic poles of the earth unless iron or steel objects are close enough to

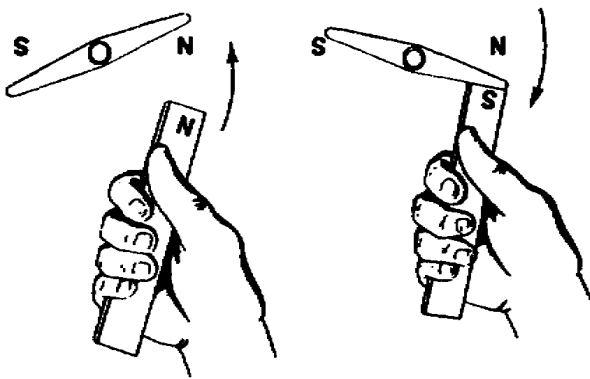

Figure 3. Attraction and repulsion between magnets.

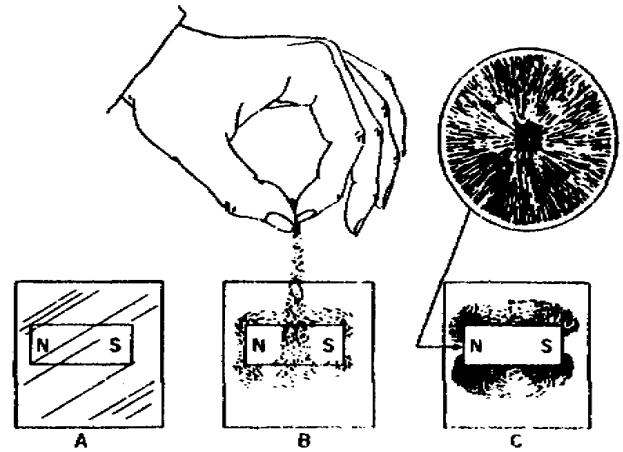

Figure 4. Pattern of a magnetic field.

affect it. When the north pole of a bar magnet is brought close to the north pole of the compass needle, they will repel each other, as shown in figure 3; but there is a strong attraction between a north pole and a south pole. This illustrates the fundamental law of magnetism which says that like poles repel while unlike poles attract. Between two magnets there is a magnetic field made up of lines of force.

1-15. This field around a magnet can be shown by placing a sheet of glass or paper over a bar magnet. As iron filings are sprinkled over the surface, they assume a definite pattern, as shown in figure 4. The magnetic field is strongest at the poles of the magnet, where the lines of force are bunched closely together. Lines of force follow a uniform distribution and never cross each other. A magnetic field may be distorted by iron or influenced by another magnetic field. A piece of soft iron will concentrate the lines of force in a field. In the same manner, two unlike poles brought near each other will have their fields linked up in common with each other.

1-16. Lodestone is a natural magnet which has been known for many centuries. From it the first compass needles were fashioned. Artificial magnets are made by exposing metal to a strong magnetic field. Hardened iron will retain magnetism over a long period of time. Alloys of aluminum and nickel make even stronger magnets.

1-17. The relationship between electricity and magnetism can be demonstrated by a strong electric current passing through a conductor. If iron filings are sprinkled over a piece of cardboard, as shown in figure 5, they will show a pattern of rings surrounding the conductor. A sensitive compass held near the wire will line up at right angles to the wire, showing that the lines of force have a definite direction. The compass needle

will swing around 180° if the current in the conductor is reversed. This requires direct current (dc) such as we get from a battery. The current from a battery is said to have only one direction, so it is called direct current. By reversing the connections of a circuit to a battery, the current in that circuit may be made to take the opposite direction.

1-18. The magnetic field produced by a single straight conductor is relatively weak. However, the field can be concentrated by forming the conductor into a coil. In this form a coil carrying an electric current shows a magnetic pattern similar to that of a bar magnet. The coil develops a north pole at one end and a south pole at the other end. The polarity may be determined by the left-hand rule which states, "If the coil is grasped with the left hand with the fingers pointing in the direction of electron flow (negative to positive), then the thumb will point toward the north pole of the coil." Electrons have a negative charge so they are attracted by a positive charge. Consequently, the electron movement in a circuit is from negative to positive. The electron movement in the conductor is indicated by two arrows figure 6.

1-19. Most coils are formed around an iron core because the core intensifies the magnetic field. The coil with its iron core is called a solenoid. Air offers resistance to the lines of force, which is called reluctance. Iron has less reluctance than air so that the lines of force will choose a path through iron rather than air when there is a choice. Forming the iron into the shape of a horseshoe makes less distance between the poles of a magnet, and the field is more concentrated. Soft iron is used for the core in electromagnets, as it will lose its magnetism when the current in the coil stops. The core is

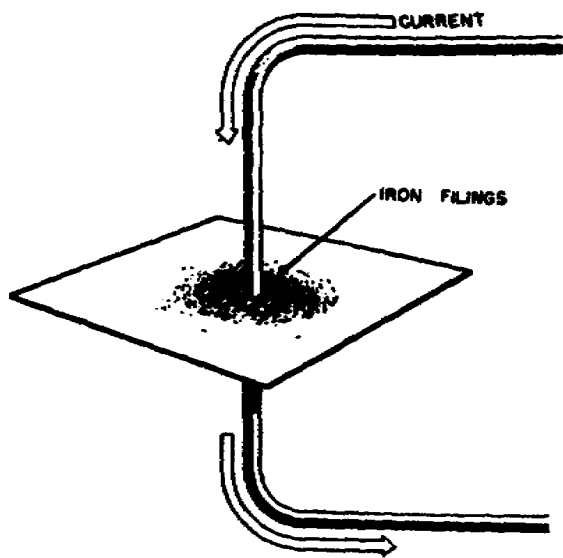

Figure 5. Electric current produces magnetic field.

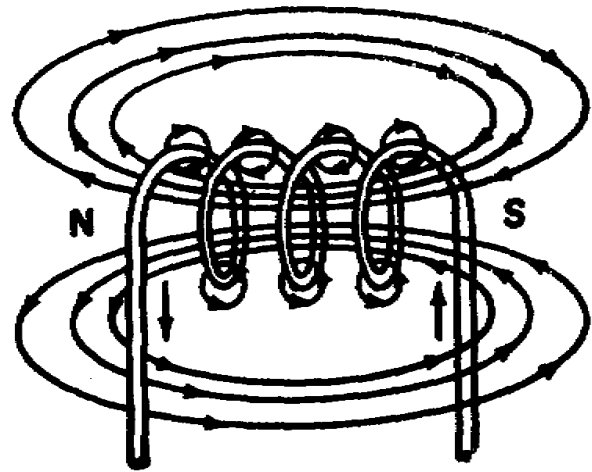

Figure 6. Magnetic field produced by a coil.

built up with thin sheets of soft iron which serve to insure the loss of magnetism when the magnetizing force is removed. An example of this is an electromagnet used for picking up and moving scrap iron in a salvage yard. The magnet is hung from a crane and may pick up a ten or more of iron at one time. When the load is moved into position to be dropped, the current to the coils is shut off. The loss of magnetism in the core allows the load to fall. The strength of the field of an electromagnet is determined by the number of turns of wire in the coils and the magnitude of the current.

1-20. **Electron Movement and Effects.** Electrons flowing through conductors cause several effects. We shall discuss some of these briefly.

1-21. **Heat.** Heat is generated as the electrons flow through the conductor. The electric coffeemaker, electric stove or heater, and such items are examples of this effect that we see each day. Light is a side effect of the heat generated.

1-22. **Light.** An incandescent lamp is made up of a filament (conductor) inclosed in an evacuated envelope. As current passes through the filament, it is heated to the point of glowing. If no air is allowed into the envelope, the filament will last a long time.

1-23. When electrons flow through an ionized gas at the right pressure and value, the gas will glow. Also, if a stream of electrons strikes certain compounds, the compounds will glow. Your TV picture gives a picture because of this effect.

1-24. **Chemical.** The chemical effect of electron movement is important. If electrons are forced to move through a solution of certain chemicals, one of the elements in the solution will come out of the solution in its natural state.

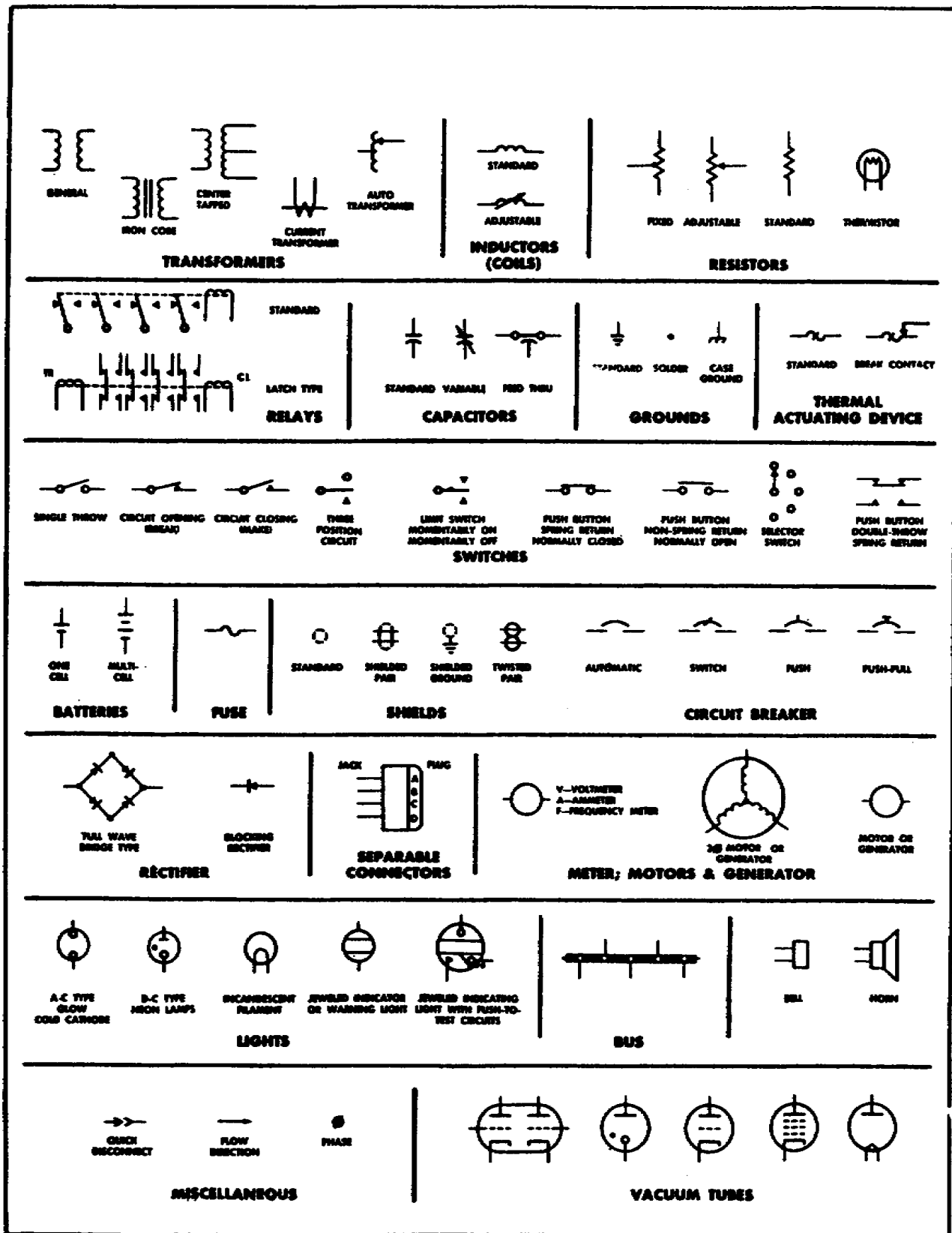

Figure 7. Basic electrical symbols.

Thus, if an electric current is sent through a solution of copper sulphate, pure copper is deposited on one of the contacts immersed in the solution. A stream of electrons reaching a contact immersed in a solution can change the chemical makeup of the contact.

1-25. **Magnetism.** Magnetic field, identical to those discussed previously are produced as a direct result of electron movements within a conductor.

1-26. **Electromagnetic Fields.** The magnetic fields produced by electric currents are called *electromagnetic fields* and are composed of lines of force like all other magnetic fields. For example, in the field around a straight wire (conductor) carrying current the lines of force are concentric circles. The force of the field is strongest close to the wire, and it weakens rapidly the greater the distance from the wire.

1-27. To determine the direction of the magnetic field about a current-carrying wire, use the left-hand thumb rule which states, "Hold your left hand as if grasping the wire in such a way that your thumb points in the direction of the current (electron) flow. The fingers of your left hand will then point in the direction of the magnetic field about the wire."

1-28. The magnetic field associated with a loop of wire is much the same as the field of a bar magnet. The loop has poles similar to those of a bar magnet, with lines of force emerging from the north pole and entering the south pole. The left-hand rule applied to the loop of wire will show you which is the north and which is the south pole.

1-29. If equal currents pass through a coil of wire consisting of 8 closely wound turns and through a single-turn loop of the same diameter as the coil, the magnetic fields will be almost identical in direction at every point. However, the magnetic field strength of the 8-turn coil will be approximately 8 times that of the single loop. This is because the fields of the 8 turns are virtually parallel to each other at every point and their effects are cumulative at every point.

1-30. If you spread out the 8 turns into a helical coil the magnetic field between the turns will be very weak. This is because the fields of adjacent turns will be opposite in direction and will tend to cancel each other. Inside and outside the coil they will be strong, for they will be cumulative. The net result will be a strong field of fairly uniform intensity, represented by nearly straight lines of force both inside and outside the coil.

1-31. Both of the coils, the one closely wound and the other spread apart, will each have a north pole at one end and a south pole at the other. The direction of the field will depend upon the direction of the current flow.

1-32. **Safety.** Anyone working with electricity must always be on his guard because of the dangers involved with electricity. Follow all rules. The basic rule is to keep clear of lines or equipment when they are energized. Do not put yourself in such a position that your body may become part of the circuit. Rules cannot be written to cover every situation; your own good judgment must govern your actions. The man who always practices safety will establish good working habits so that he will naturally do his work in a safe manner. The man who neglects safety is a menace to himself and to those working around him. Carelessness or a devil-may-care attitude should not be tolerated; either will eventually lead to the destruction of life or property.

1-33. Study the information in figure 7 so that you can recognize and identify each item. These symbols will be used in this chapter to make schematic diagrams of circuits. The purpose and application of these device will be explained in the discussion of circuits.

1-34. An example of the use of symbols is shown in figure 8. The upper part shows a picture of a toaster, a percolator, and a hot plate. Each of these has a resistance element which converts electricity into heat when the appliance is plugged into an outlet. The lower part of the figure show how these items would be repre-

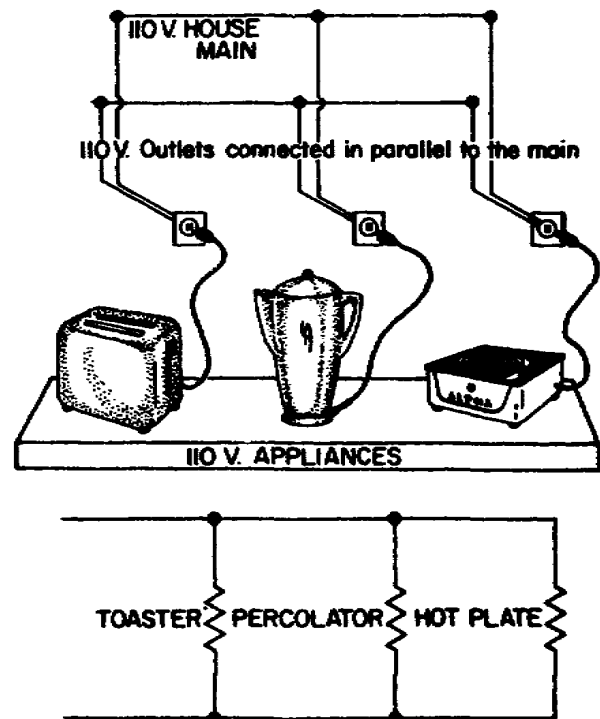

Figure 8. Comparison between picture and symbol representation.

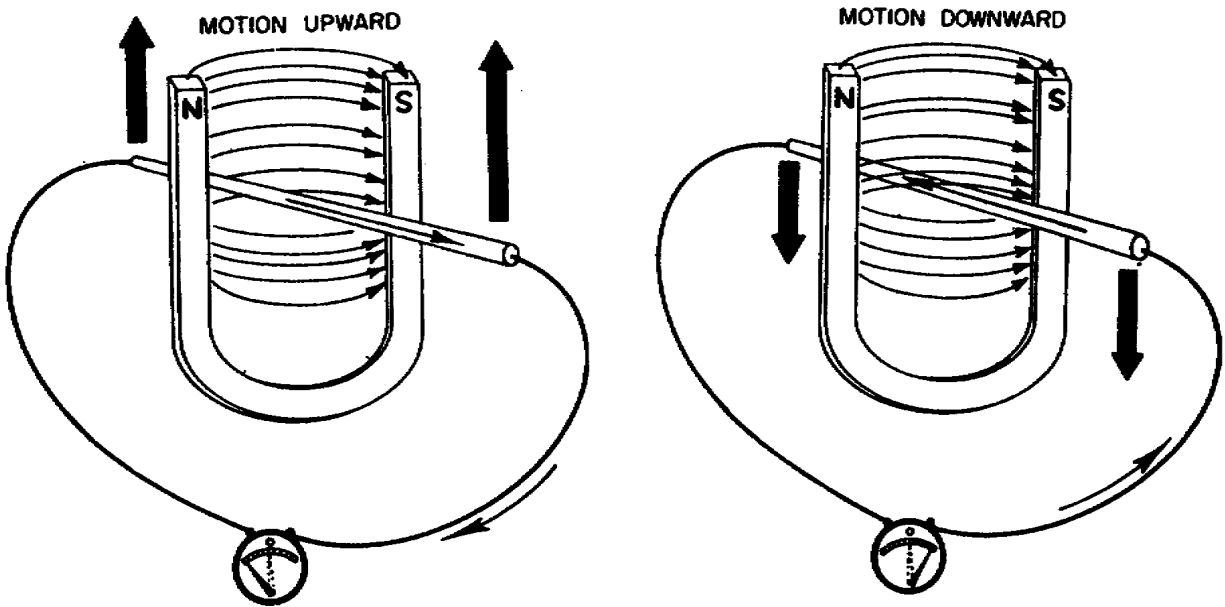

Figure 9. Inducing voltage by moving a conductor through a field.

sented in a schematic diagram. Each item is shown by the same resistance symbol and must be identified with labels to distinguish which is which. Notice how much simpler the schematic diagram appears and yet it conveys the same information from an electrical standpoint as the more complex picture. You could easily draw the diagram in less than a minute and it would tell another technician the same story - that there were three appliances connected to a suitable source.

2. Production of Electromotive Force

2-1. A generator is a machine which converts mechanical energy into electrical energy. First, the generator must have some source of mechanical energy. The type of machinery used to supply this energy to the generator is usually called the *prime mover*.

2-2. There are a number of methods used as prime movers. Water power (hydroelectric) normally has low operating costs, but high installation costs. Steam power (steam turbine) has a low installation and operating cost when used for plants of 15,000-kw capacity or more. Diesel engines are used a great deal in plants where the capacity required is from 2,000 w to 15,000 kw. However, there are low-speed and high-speed diesel engines. The high-speed diesel engine has a lower installation cost than the low-speed type, but its life is not as long. Gasoline engines should not be chosen to drive generators in plants which require continuous power because their fuel and maintenance costs are too high. The gasoline engines are usually used for small portable units.

2-3. The electrical power output from a generator may be either direct current (dc) or alternating current (ac), depending upon the construction. However, in principle, the rotating coils and the magnetic field through which they turn are the same for both types of generators. The primary difference between ac and dc generators is the method by which the current is taken from the machine.

2-4. In a generator we have two set of coils and a field: one set of coils is in motion and the other set of coils acts as an electromagnet to set up a magnetic field. Figure 9 shows how a conductor moving across a magnetic field has a voltage induced in it. The galvanometer connected to the conductor has the zero position of the pointer in the center of the scale so that it can read current in either direction. As the conductor is moved upward through the field, the galvanometer needle is deflected to the left. When the conductor is moved downward, the galvanometer needle is deflected to the right, showing that the direction of current in the conductor is reversed.

2-5. **Direct-Current Generator.** A simplified diagram of a dc generator is illustrated in figure 10. A loop of wire represents the conductor that rotates in the magnetic field. The ends the loop terminate in two copper half rings which are insulated from each other. Fixed brushes make a contact with the copper to conduct electricity to the external circuit. The loop is rotated a clockwise direction. In position A, the lines of force are not being cut by the armature conductors but no voltage is produced. In position , with the black half of the armature conductor

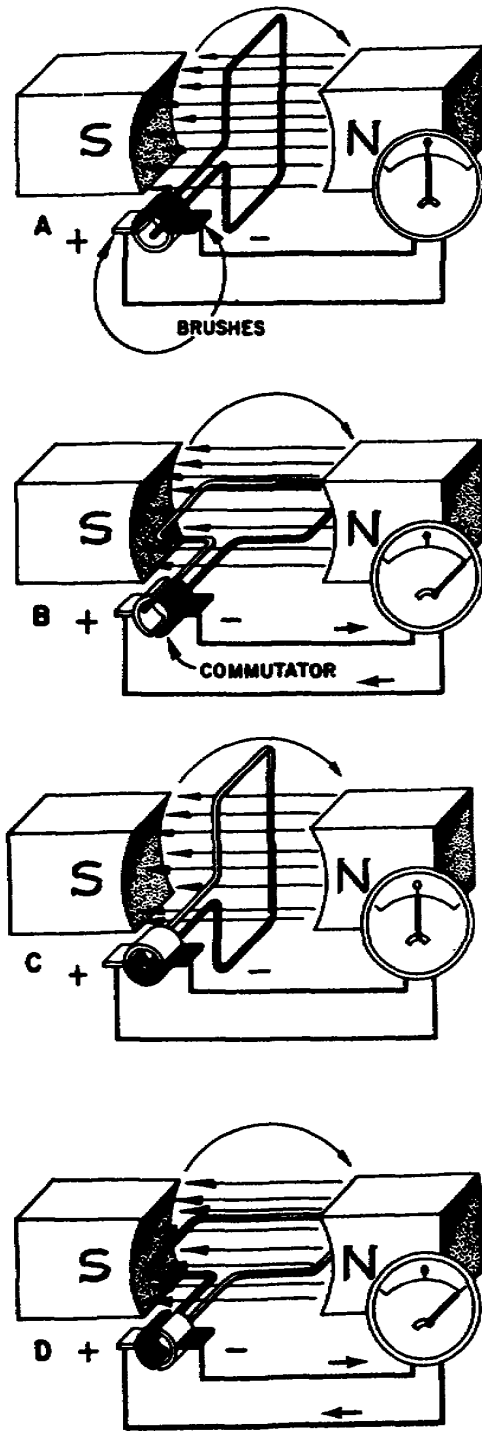

Figure 10. Simplified diagram of a direct-current generator.

toward the north pole and the black half-ring against the negative brush, the armature conductor is cutting the maximum lines of force. At this position maximum voltage is induced into the armature conductors with the current flow through the galvanometer as indicated in figure 10. At position C, the armature conductor has rotated 180° from position A and again no voltage is produced. In position D, with the white half of the armature conductor toward the north pole and with the white half-ring against the negative brush, the armature conductor again is cutting the maximum lines of force, with maximum voltage being induced into the armature conductors and with the current flow through the galvanometer in the same direction as position B. Check the black brush in the figure at positions B and D and you will see that the sides of the armature conductor change but the brushes are stationary; they deliver direct current because either armature conductor in contact with the black brush will have the same direction of motion across the field.

2-6. A direct-current generator is quite different from the working model shown in figure 10. Instead of permanent magnet, strong electromagnets are used. The strength of the field can be controlled by changing the current in the field coil. A variable resistance in the field circuit makes it possible to control the voltage output of the generator. Instead of a single loop, there are many coils of wire in the rotor. The ends of each coil terminate in opposite copper segment. These copper segments are formed in a ring called the commutator. The rotor assembly illustrated figure 11 is an armature for a dc generator.

2-7. The ends of the armature shaft ride in bearings. The three main parts of a generator are the stator, the rotor, and the end bells. The main frame of the generator holds the stator or field. This frame supports the end bells which carry the bearings. One end bell contain the brush rig which holds the brushes. The voltage generated is controlled by a rheostat in the field circuit that changes the strength of the electromagnets. A change in speed would also change the voltage, but it is much simpler to control by resistance.

2-8. **Alternating-Current Generator.** A simplified diagram of an ac generator is shown figure 12. The difference between the dc generator and the ac generator is in the method used to deliver the current to the brushes. In the ac generator, sliprings are used instead of a commutator. This means that the same side of the loop delivers current to the same brush re-

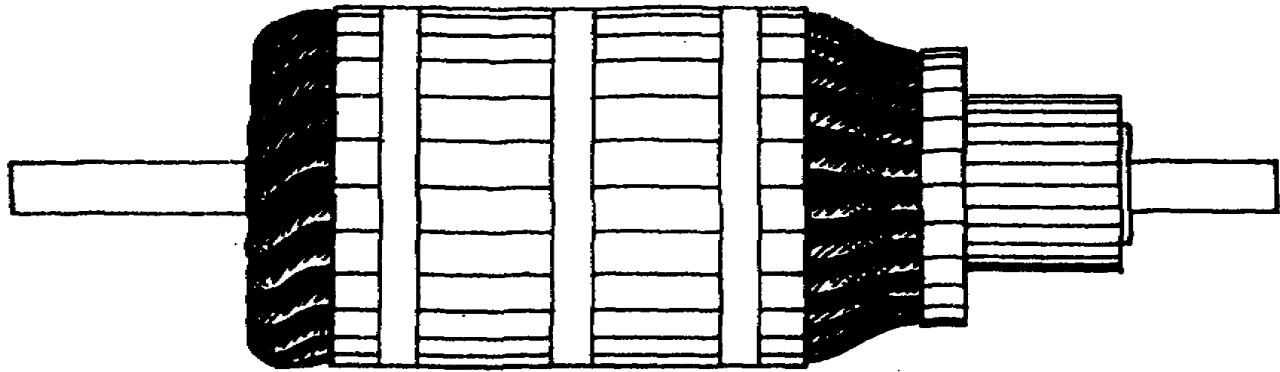

Figure 11. DC generator armature.

ardless of rotation; otherwise the operation is the same.

2-9. The illustration shows the loop turning in a clockwise direction. At position A, the lines of force are not being cut by the armature conductor so no voltage is produced. At position B, the armature conductor is cutting the maximum lines of force, and the galvanometer indicates the direction of current flow by the needle pointing to the right. At position C, the galvanometer again shows zero because the lines of force are not being cut by the armature conductor. At position D, the armature conductor are again cutting the maximum lines of force, and the galvanometer again shows a current flow but in the opposite direction. What happened? At position B, the black side of the loop is moving down through the field and the black slipring is negative, sending current toward the meter. At position D, the black side of the loop is moving up through the field. Now the black slipring is positive. Current is directed from the white slip ring to the meter and back. The direction of current in the loop reversed itself and the same is true in the external circuit to the meter. The loop in the dc generator operated the same way but the commutator acted as a mechanical device to direct the current in only one direction to the external circuit.

2-10. The output frequency, or cycles, of an ac generator is determined by its speed and the number of poles. A two-pole machine must be driven at 3600 rpm to produce 60 cycles per second. A four-pole machine requires a speed of 1800 rpm for a frequency of 60 cycles. The formula for frequency is

$$f = \frac{P \times S}{2 \times 60}$$

where f is the frequency, P is the number of poles, and S is the speed rpm. The output voltage is controlled in the same manner as described for a dc generator. A rheostat in series with the field is used to change the strength of the field magnet; the stronger the field, the greater the voltage generated.

2-11. The simple ac generator discussed here would produce single-phase current, as there is only one loop or winding. A three-phase generator requires three sets of windings and each winding produces one phase. The windings are physically displaced from each other 120° apart so that maximum voltage in one winding is generated at a different time from that in the other windings. At least three wires are needed to deliver three-phase electrical power from the generator to equipment. A single-phase voltage and current is developed between any two of the wires. Phases may be designated by number or as A, B, C, for identification. Figure 13 shows the pattern of a three-phase current for one complete cycle. A peak occurs every 60°, or 6 times for each cycle. The same pattern of rise and fall should be used to illustrate the cycle of three-phase voltage.

3. Direct Current Fundamentals

3-1. In order for current to flow, two things are essential: there must be a source of electrical pressure (voltage) and there must be a complete circuit. The source of voltage may be a battery, a generator, or some other device. The complete circuit requirement means that there must be a complete path from the negative terminal through the load and back to the positive terminal of the source. The complete path should allow the electrons to flow freely to the load, do their work in the load, and then move freely back to the source.

3-2. However desirable this condition is, it cannot be completely achieved since no material used as a conductor (wire) allows the electrons to move with complete freedom. There is always some resistance to the electron flow. All conductors have some resistance; just how much they have depends on the size and length of the con-

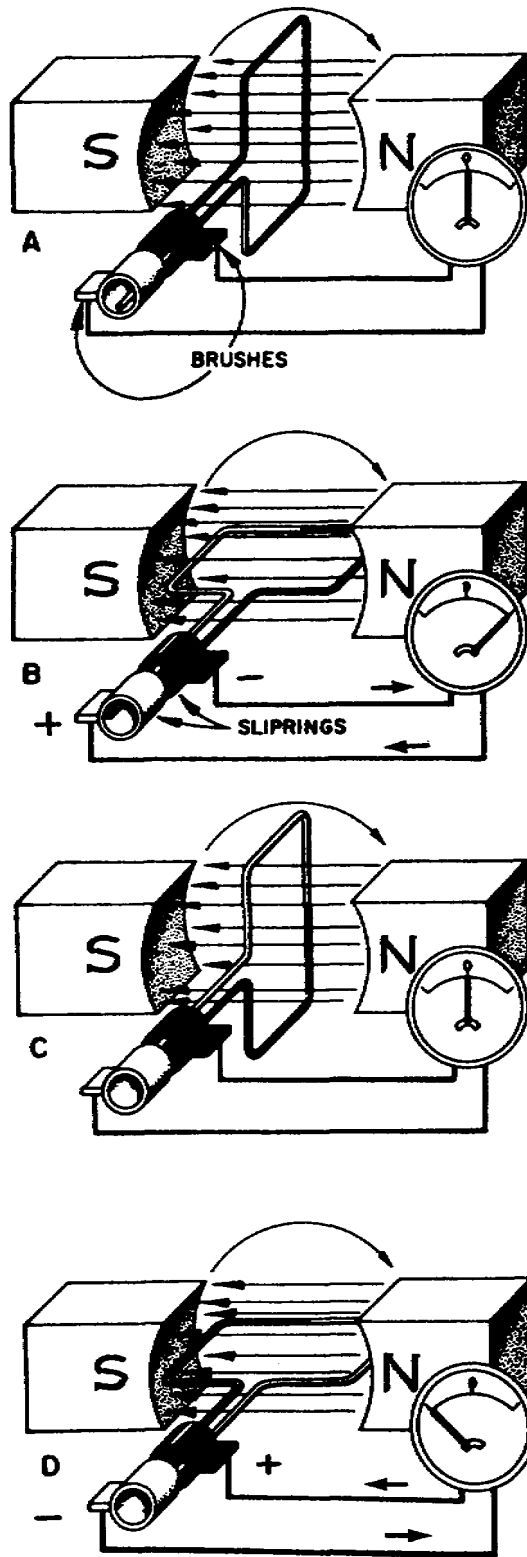

Figure 12. Simplified diagram of an alternating-current generator.

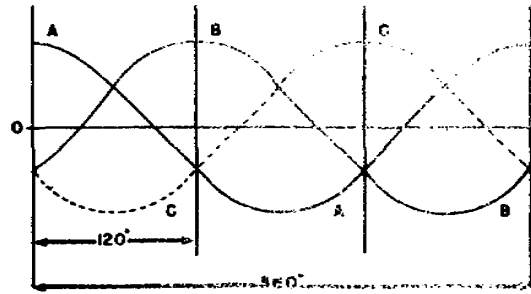

Figure 13. One cycle of a three-phase current.

ductors as well as on the materials of which they are made.

3-3. The source of voltage is any device which has an excess of electrons in one place over the number of electrons in another place. Connecting the two places by means of an electrical circuit, including resistance, permits the two places to try to equalize the number of electrons. The movement of electrons that results from this attempt is what is known as current.

3-4. **Ohm's Law and DC Circuit.** Since Ohm's law contains two separate thoughts, it may be expressed in the following two statements: (1) Current in any electrical circuit is directly proportional to the voltage, and (2) current in any electrical circuit is inversely proportional to the resistance. Ohm's law is more generally stated as follows: The current in a circuit is equal to the voltage divided by the resistance. Mathematically, it is expressed as:

$$I = \frac{E}{R} \quad (1)$$

In this equation, I stands for the current in amperes, E for the voltage in volts, and R for the resistance in ohms. Thus, if the source of potential is a 6-volt battery and the electrical device is a bulb having 3 ohms of resistance, the current will be:

$$\frac{6}{3} = 2 \text{ amperes}$$

3-5. The equation for Ohm's law can be converted mathematically to read as follows:

$$E = I \times R \quad (2)$$

By use of this equation, you can determine the voltage across a component of a circuit if you know the unit's resistance and the current flow through it. Thus, if you know that the current through a lamp is 2 amperes and the resistance of the lamp is 3 ohms, you know that the voltage across it must be 3×2 , or 6 volts.

3-6. The equation for Ohm's law can be converted mathematically in still another way to read:

$$R = \frac{E}{I} \quad (3)$$

Using equation 3, you can determine the resistance of any circuit component if you know the voltage across it and the current flowing through it. Suppose you know that the voltage across a lamp is 6 volts and the current through it is 2 amperes. You can find the lamp's resistance by substituting in equation 3:

$$\begin{aligned} R &= \frac{E}{I} \\ &= \frac{6}{2} \\ &= \mathbf{3 \text{ ohms}} \end{aligned}$$

3-7. Using these three equations enables you to find any one of the three quantities - voltage, current, or resistance - if you know the other two.

3-8. **Series Circuits.** A series circuit is one in which there is only one path through which the current can flow. In figure 14 three resistances and a battery are connected to form a series circuit. Since there is but one path for the current all of the current passes through each resistance and the current is the same throughout the entire circuit, or

$$I_t = I_1 = I_2 = I_3, \text{ etc.} \quad (4)$$

3-9. The total voltage drop in the series circuit is equal to the sum of the voltages (voltage drops) across the individual resistors, or

$$E_t = E_1 + E_2 + E_3, \text{ etc.} \quad (5)$$

3-10. The total resistance of the circuit is equal to the sum of the resistances of the individual units, or

$$R_t = R_1 + R_2 + R_3, \text{ etc.} \quad (6)$$

3-11. If one of the devices in a series circuit burns out, there is no longer a complete path for the current and, therefore, the other devices the circuit will not operate.

3-12. *Problem:* In figure 14, three resistances are connected in series across a 24-volt power source. The voltages and currents are measured and found to be as indicated in the illustration. Find:

- The total voltage drop.
- The total current.
- The resistance of each unit.
- The total resistance.

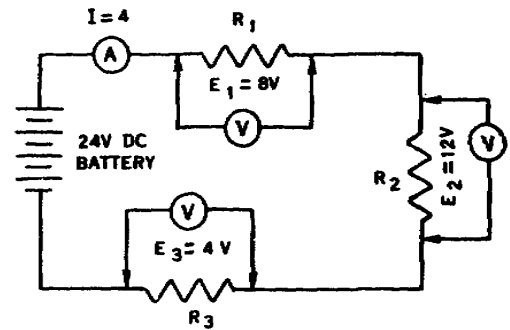

Figure 14. Series circuit.

Solution:

- Using equation 5:
 $E = 8 + 12 + 4 = 24 \text{ volts}$
- Using equation 4:
 $I_t = 4 = 4 = 4 \text{ amperes}$
- Using equation 3, the resistance of each unit is computed as follows:

$$R_1 = \frac{E_1}{I} = \frac{8}{4} = \mathbf{2 \text{ ohms}}$$

$$R_2 = \frac{E_2}{I} = \frac{12}{4} = \mathbf{3 \text{ ohms}}$$

$$R_3 = \frac{E_3}{I} = \frac{4}{4} = \mathbf{1 \text{ ohm}}$$

- Using equation 6:

$$R_t = 2 + 3 + 1 = 6 \text{ ohms}$$

Check:

Using equation 3, the total resistance can also be computed as follows:

$$R_t = \frac{E_t}{I_t} = \frac{24}{4} = \mathbf{6 \text{ ohms}}$$

3-13. **Parallel Circuits.** In a parallel circuit, two or more electrical devices provide independent paths through which the current may flow. The voltage across each device so connected in parallel is the same, or

$$E_t = E_1 = E_2 = E_3, \text{ etc.} \quad (7)$$

3-14. The total current in the circuit is equal to the sum of the individual currents flowing through the parallel-connected devices, or

$$I_t = I_1 + I_2 + I_3, \text{ etc.} \quad (8)$$

3-15. Thus, the total amount of current in a parallel circuit is greater than the current in any one individual branch or leg, and consequently the total resistance must be less than the value of the smallest resistance in the circuit. The greater the number of electrical devices or resistors connected in parallel in a given circuit, the greater will be the total current, and the smaller will be the total resistance of the circuit.

3-16. Electrical devices are connected in parallel in any installation in order to: (1) decrease the total resistance of the circuit and (2) allow the units to operate independently of each other. In a parallel circuit, if one unit burns out it does not affect the operation of the other units; one path is broken but the other circuits are still complete.

3-17. There are several ways to calculate the total resistance of a parallel circuit. We shall show the simpler way first, which is the product over the sum method, and then give you the more complex general rule.

3-18. To calculate the total resistance of the parallel circuit shown in figure 15, use the following equation and solve for the equivalent resistance of only two paths at a time.

$$R_t = \frac{R_{1st\ unit} \times R_{2d\ unit}}{R_{1st\ unit} + R_{2d\ unit}} \quad (9)$$

3-19. When the load units that are connected in parallel all have the same resistance value, the previous equation may be simplified to read:

$$R_t = \frac{\text{Resistance of one unit}}{\text{Number of like units}} \quad (9A)$$

3-20. *Problem:* In the illustration accompanying the previous discussion, three load units are connected in parallel. Using the resistance values indicated, find the total resistance.

Solution:

a. Using equation 9, for the first two paths

$$\begin{aligned} R_{(1\ and\ 2)} &= \frac{12 \times 4}{12 + 4} \text{ ohms} \\ &= \frac{48}{16} \text{ ohms} \\ &= 3 \text{ ohms} \end{aligned}$$

b. Since 3 ohms is the equivalent resistance of the first two paths you may substitute a 3-ohm resistor for them, and adding the 6ohm resistor of the third path redraw the circuit as shown at the right in the illustration.

c. Then, combing $R_{(1\ and\ 2)}$ with R_3 and using equation 9 again, you have

$$\begin{aligned} R_t &= \frac{R_{(1\ and\ 2)} \times R_3}{R_{(1\ and\ 2)} + R_3} \\ &= \frac{3 \times 6}{3 + 6} \text{ ohms} \\ &= \frac{18}{9} \text{ ohms} \\ &= 2 \text{ ohms} \end{aligned}$$

3-21. The general equation for finding the total resistance in a parallel circuit is known as the reciprocal method. It involves determining the reciprocal of the sum of the reciprocals of the individual resistances. In other words, find a common denominator and divide the resistances

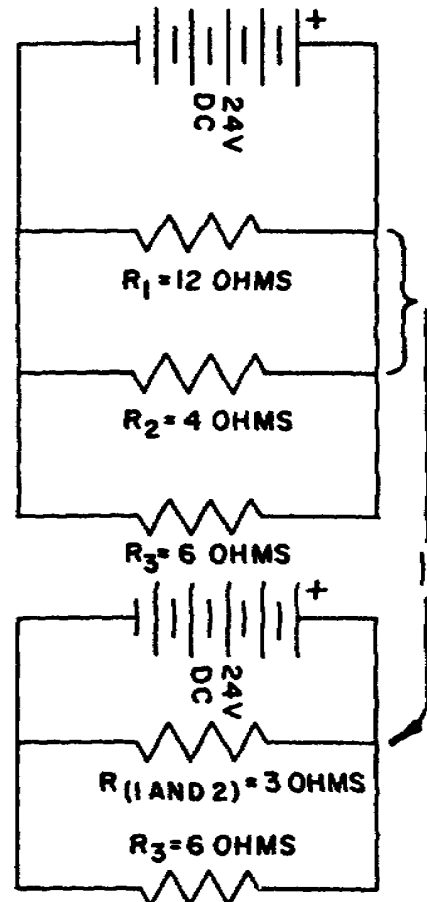

Figure 15. Parallel circuit.

into the common denominator, then add and invert, and divide this sum to find the total resistance.

$$\frac{1}{R_t} = \frac{1}{R_1} + \frac{1}{R_2} + \frac{1}{R_3} \quad (10)$$

3-22. Using equation 10, the total resistance can be computed as follows:

$$\frac{1}{R_t} = \frac{1}{12} + \frac{1}{4} = \frac{1}{6} \text{ ohms}$$

$$\frac{1}{R_t} = \frac{1}{12} + \frac{3}{12} + \frac{2}{12} \text{ ohms}$$

$$\frac{1}{R_t} = \frac{6}{12} \text{ ohms}$$

$$6R_t = 12 \text{ ohms}$$

$$R_t = 2 \text{ ohms}$$

3-23. **Series-Parallel Circuit.** As shown in figure 16, in a series-parallel circuit some of the units are connected in series with each other, while other units are connected in parallel. To solve a series-parallel problem, first convert it to a series circuit by substituting an equivalent resistance for the parallel resistances; then solve the series circuit problem as explained previously.

3-24. *Problem:* In the illustration of the series-parallel circuit a resistor is connected in series with four lamps which are connected in parallel with each other. The voltage and resistances were measured and found to be as indicated. Find the current through the various parts of the circuit.

Solution:

a. The resistance of each lamp is 4 ohms. Therefore, using equation 9A, the equivalent resistance of the four lamps in parallel is

$$R_t = \frac{4}{4} = 1 \text{ ohm}$$

b. Substituting a 1-ohm resistor for the four lamps and using equation 6, you find the total resistance of the circuit as follows:

$$R_4 = 5 + 1 = 6 \text{ ohm}$$

c. Using equation 1, you compute the total current in the circuit to be

$$I = \frac{24}{6} = 4 \text{ amperes}$$

d. Since the total current must flow through the series resistor, the current flow through it must be 4 amperes.

e. Since the total current flowing through the four lamps is 4 amperes and since they all have the same value of resistance, the current must divide evenly among the lamps and is therefore found to be 1 ampere through each lamp circuit.

3-25. **Power.** Besides the current, voltage, and resistance of a circuit, the power must also be considered. Power is defined as the rate of doing work, and it is measured in a variety of units. An electric motor, for example, is rated in terms of horsepower. One horsepower is the rate of doing work when a 550-pound weight is raised a distance of 1 foot in 1 second. Some motors develop 5000 or more horsepower. Electrical

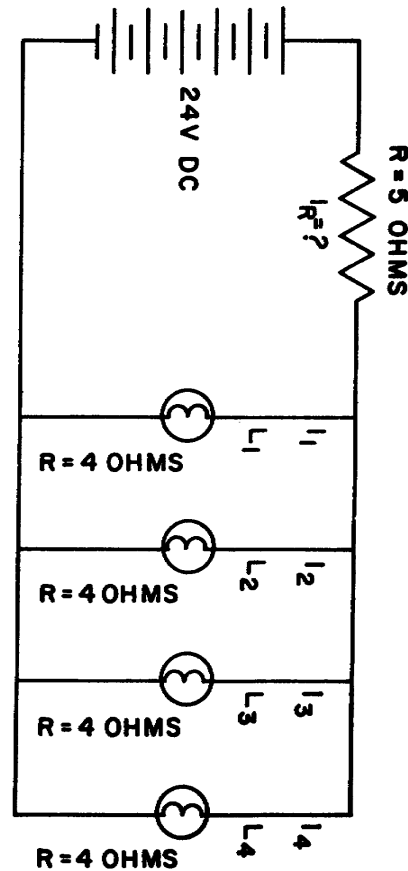

Figure 16. Series-parallel circuit.

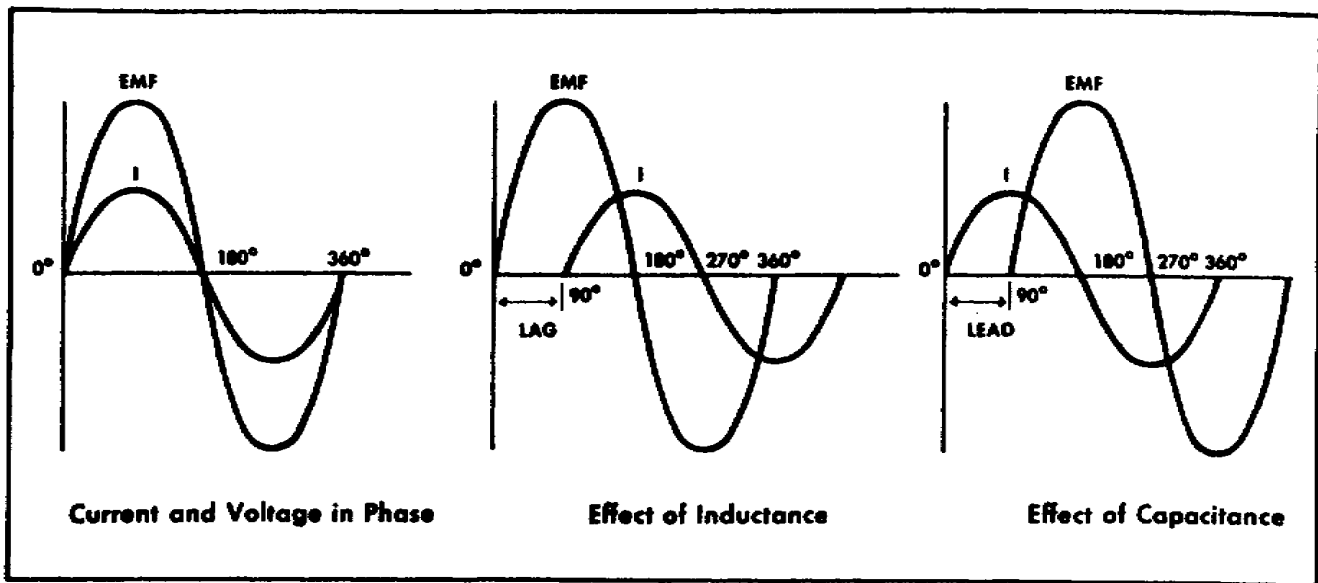

Figure 17. Sine wave of current and voltage.

power is generally expressed in terms of watts. A watt is the power consumed in a circuit through which 1 ampere flows under a pressure of 1 volt. One horsepower equals 746 watts.

3-26. Most electrical devices are rated according to the voltage that should be applied to them and also according to the amount of power they require. For example one lamp might be rated as a 115-volt, 40-watt lamp, while another might be rated as a 115-volt, 20-watt lamp. This means that both lamps are to be operated on a 115-volt circuit, but that twice as much power is required to operate the first lamp as the second.

3-27. You can compute the wattage of an electrical unit - that is, the power it requires - by multiplying the value of the current flowing through it by the value of the voltage applied to it.

$$P = I \times E \quad (11)$$

Thus, a starter motor drawing 70 amperes at a potential of 24 volts is using 1680 watts of electrical power. To convert electrical power (wattage) to horsepower, divide the electrical power rating by 746. Thus, by dividing 1680 watts by 746-watts (the electrical equivalent of 1 horsepower) you will find that the starter motor will develop approximately 2.25 horsepower.

4. Alternating-Current Fundamentals

4-1. In a dc circuit, current moves in one direction, from the negative terminal of the source through the circuit to the positive terminal. In ac circuits, the current flows first in one direction and then in the opposite direction, thus the name "alternating current."

4-2. Alternating current has largely replaced direct current for a number of reasons, namely: (1) ac voltages can be increased or decreased very efficiently with transformers, (2) ac devices are much simpler and consequently are less prone to trouble than are dc devices, (3) ac units are much lighter, and (4) they operate more efficiently.

4-3. Most electrical appliances manufactured in the United States have a small "data plate" which gives the electrical information necessary for connecting the appliances to the proper electrical circuits. This data plate usually gives the voltage, frequency (cycles per second), horsepower (size of motor) or watts (for heating units), amperes, ac or dc, and the power factor. If you connect electrical appliances per the information on the data plate, they usually give a long life of uninterrupted service.

4-4. **Phase of Current and Voltage.** When current and voltage pass through their zero value and reach their maximum value at the same time, the current and voltage are said to be in phase. If the current and voltage pass through zero and reach their maximum values at different times, the current and voltage are said to be out of phase. In a purely inductive circuit the current reaches a maximum value later than the voltage, lagging the voltage by 90°, or one-fourth of a cycle. In a circuit containing only capacitance, the current reaches its maximum ahead of the voltage, and the current leads the voltage by 90°, or one-fourth of a cycle.

4-5. Figure 17 shows graphically the in-phase condition and the effect of inductance and capacitance on this phase relationship. The current will never lead or lag the voltage by exactly

90° because of the resistance of the conductor. The number of degrees by which the current leads or lags the voltage in a circuit depends on the relative amounts of resistance, capacitance, and inductance in the circuit.

4-6. **Inductance.** When an alternating current flows through a coil of wire, it sets up an expanding and collapsing magnetic field about the coil. The expanding and collapsing magnetic field induces a voltage within the conductor proper which is opposite in direction to the applied voltage.

4-7. This induced voltage opposes the applied voltage, thus serving to lessen the effect of the applied voltage. This results in the self-induced voltage tending to keep a current moving when the applied voltage is decreasing and to oppose a current when the applied voltage is increasing. This property of a coil which opposes any change in the value of the current flowing through it is called *inductance*.

4-8. The inductance of a coil is measured in henrys, and the symbol for inductance is L. In any coil the inductance depends on several factors, principal of which are the number of turns of wire in the coil, the cross-sectional area of the coil, and the material in the center of the coil, or the core. A core of magnetic material greatly increases the inductance of the coil.

4-9. Remember, however, that even a straight wire has inductance, small though it may be when compared to that of a coil. All ac motors, relays, transformers, and the like contribute inductance to a circuit.

4-10. **Capacitance.** Another important property of ac circuits, besides resistance and inductance, is capacitance. While inductance is represented in a circuit by a coil and resistance by a resistor, capacitance is represented by a capacitor. Any two conductors separated by a nonconductor constitute a capacitor. The capacitor is used in an electrical circuit to momentarily store electricity, smooth out pulsating dc, give more torque to a motor by causing the current to lead the voltage (see fig. 17), reduce arcing of contact points, and hasten the collapse of the magnetic field of an ignition coil to produce a hotter spark.

4-11. **Power in AC Circuits.** In a dc circuit, we calculate power by using equation 11, where the volts times the amperes equal the watts (power). Thus, if 1 ampere flows in a circuit at a potential of 200 volts, the power is equal to 200 watts. The product of the voltage and the amperage is the true power of the circuit in this case.

4-12.

In an ac circuit, however, the voltmeter indicates the effective voltage and an ammeter indicates the effective current. The product of these two indicate what is called apparent power. The relationship between true power, reactive power, and apparent power is shown graphically in figure 18. Only when the ac circuit is made

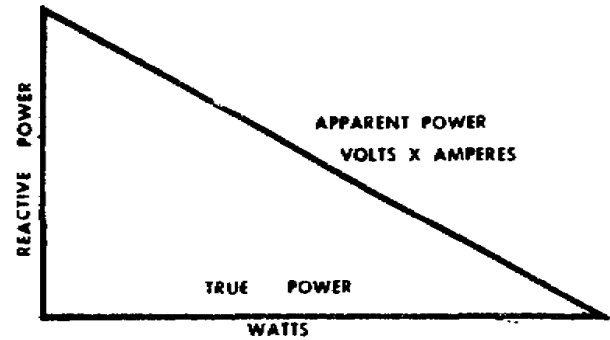

Figure 18. Power relations in an ac circuit.

up of pure resistance is the apparent power equal to the true power.

4-13. When there is capacitance or inductance in the circuit, the current and voltage are not exactly in phase with each other, and the true power is less than the apparent power. The true power is obtained by a wattmeter indication. The ratio of the true power to the apparent power is called the power factor of the load and is usually expressed as a percentage. In equation form the relationship is:

$$\text{Power factor} = \frac{100 \times \text{watts (true power)}}{\text{volts} \times \text{amperes (apparent power)}} \quad (12)$$

4-14. *Problem:* A 220-volt motor draws 50 amperes from the supply lines, but the wattmeter indicates that only 9350 watts are taken by the motor. What is the apparent power and what is the power factor of the circuit?

Solution:

a. Apparent power = 220 X 50 = 11,000 volt-amperes.

b. Using equation 12,

$$\begin{aligned} \text{PF} &= \frac{9350 \times 100}{11,000} \\ &= 85, \text{ or } 85\%, \text{ the power factor} \end{aligned}$$

5. Transformers

5-1. A transformer is an apparatus which transforms electrical energy at one voltage into electrical energy at another voltage. It consists of two coils which are not electrically connected (except auto transformers) but are arranged so that the magnetic flux surrounding one coil cuts through the other coil upon buildup or collapse of the magnetic field. When there is an alternating current in one coil, the varying magnetic flux

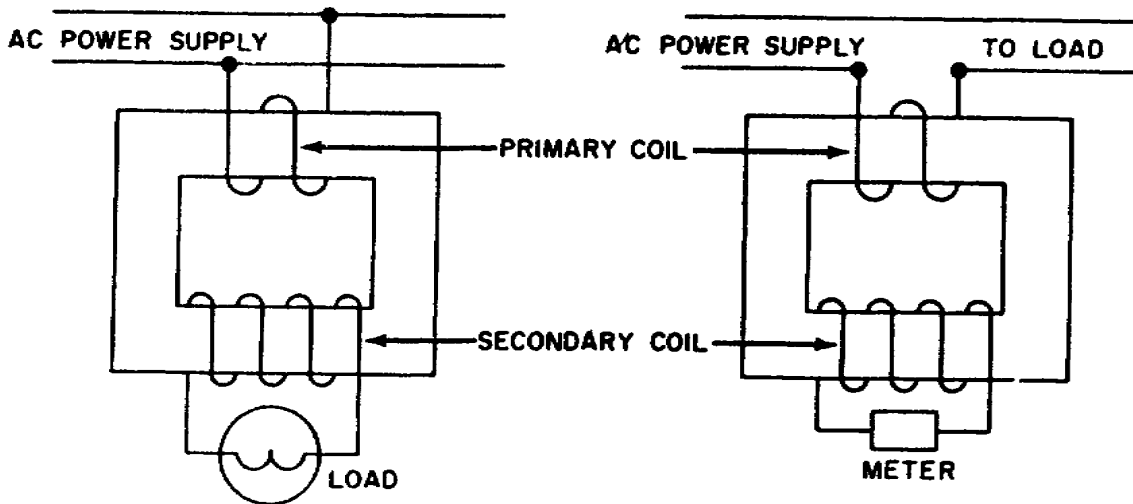
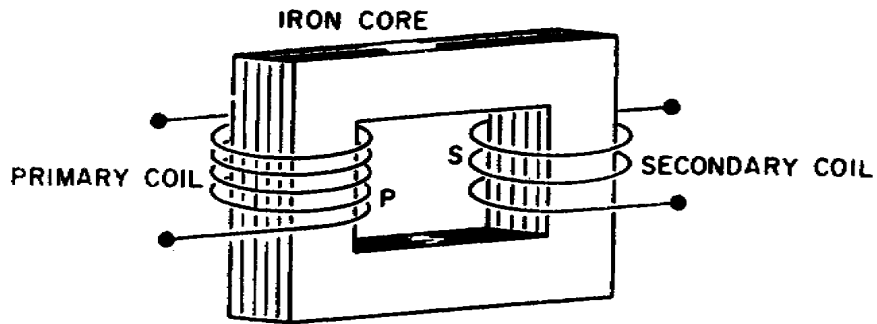

Figure 19. Voltage and current transformer.

creates an alternating voltage in the other winding by mutual induction. A transformer will also operate on pulsating dc but not on pure dc.

5-2. A transformer consists of three primary parts: an iron core, which provides a circuit of low reluctance for the magnetic flux; a primary winding, which receives the electrical energy from the supply source; and a secondary winding, which receives electrical energy by induction from the primary and delivers it to the secondary circuit.

5-3. The primary and secondary coils are usually wound, one upon the other, on a closed core obtain maximum inductive effect between them. The turns of insulated wire and layers of the coil are well insulated from each other by layers of impregnated paper or mica. The iron core is laminated to minimize magnetic current losses (eddy losses) and is usually made of specially prepared silicon steels since these steels have a low hysteresis loss. (Hysteresis loss is the portion of the magnetic energy converted to heat and lost to the system so far as useful work is concerned. It occurs with changing magnetic polarity.)

5-4. There are two classes of transformer - voltage transformers for stepping up or stepping down voltages, and current transformers which are generally used in instrument circuits. In voltage transformers the primary coils are connected in parallel across the supply voltage, as seen in figure 19. In current transformers the primary windings are connected in series in the primary circuit.

5-5. Of the two types, the voltage transformer is the more common. There are also power-distributing transformers for use with high voltages and heavy loads. Transformers are usually rated in kilovolt-amperes.

5-6. **Principles of Operation.** When an alternating voltage is connected across the primary terminals of a transformer, an alternating current will flow and self-induce in the primary coil a voltage which is opposite and nearly equal to the connected voltage. The difference between these two voltages will allow just enough current to flow in the primary coil to magnetize its iron core. This is called the exciting (magnetizing) current.

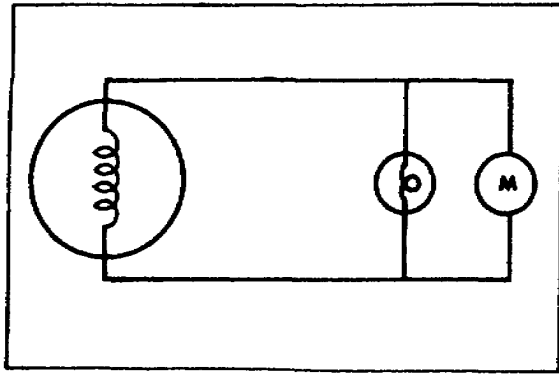

Figure 20. Single-phase generator and load.

5-7. The magnetic field caused by the exciting current cuts across the secondary coil and induces a secondary voltage by mutual induction. If a load is connected across the secondary coil of the transformer, the load current flowing through the secondary coil will produce a magnetic field which will tend to neutralize the magnetic field produced by the primary current. This, in turn, will reduce the self-induced (opposition) voltage in the primary coil and allow more primary current to flow.

5-8. The primary current increases as the secondary load current increases, and decreases as the secondary load current decreases. When the secondary load is removed, the primary current is again reduced to the small exciting current sufficient only to magnetize the iron core of the transformer.

5-9. Connecting Transformers in an AC Circuit.

Before studying the various uses of transformers and the different ways of connecting them, you should understand the difference between a single-phase circuit and a three-phase circuit.

5-10. A single-phase circuit is a circuit in which the voltage is generated by an alternator, as shown in figure 20. This single-phase voltage may be taken from a single-phase alternator or from one phase of a three-phase alternator, as explained later.

5-11. A three-phase circuit is a circuit in which three voltages are generated by an alternator with three coils so spaced within the alternator that the three voltages generated are equal but reach their maximum values at different times, as shown figure 21. In each phase of a 60-cycle, three-phase generator, a cycle is generated every 1/60 second.

5-12. In its rotation, the magnetic pole passes one coil and generates a maximum voltage; one-third of a cycle (1/180 second) later, this same pole passes another coil and generates a maximum voltage in it; and one-third of a cycle later, it passes still another coil and generates a

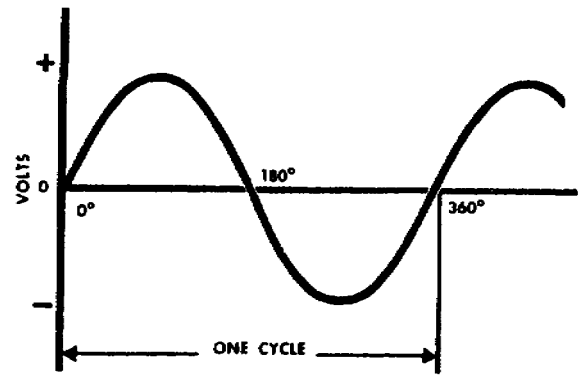

Output of a Single-Phase Alternator

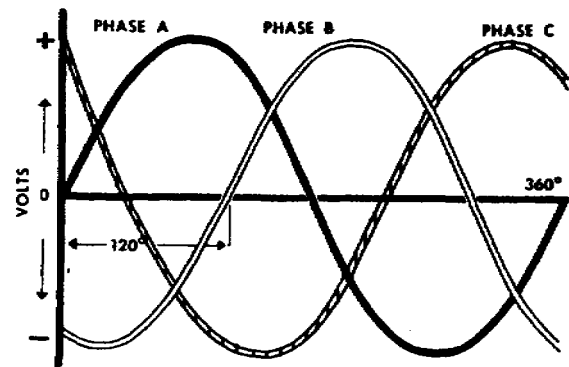

Figure 21. Sine wave of voltage outputs of single- and three-phase generators.

maximum voltage in it. This causes the maximum voltages generated in the three coils always to be one-third of a cycle (1/180 second) apart.

5-13. Three-phase motors and other three-phase loads are connected with their coils or load elements arranged so that three transmission lines are required for delivery of power. (See fig. 22.) Transformers that are used for stepping the voltage up or down in a three-phase circuit are electrically connected so that power is delivered to the primary and taken from the secondary by the standard three-wire system.

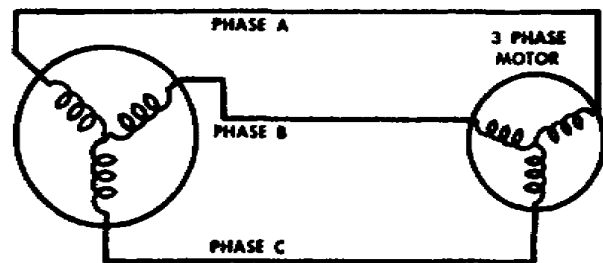

Figure 22. Three-phase generator with three conductors.

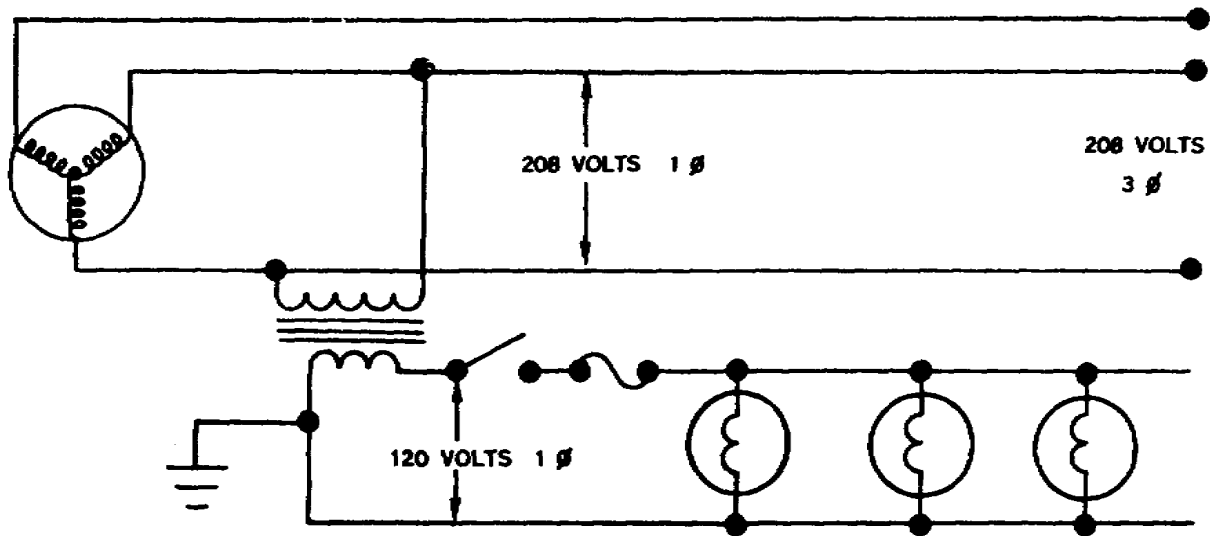

Figure 23. Step-down transformer, two-wire system.

5-14. However, single-phase transformers may be connected across any two phases of a three-phase circuit, as shown figure 23. When single-phase loads are connected to three-phase circuits, the loads are distributed equally among the three phases in order to balance the loads on the three generator coils.

5-15. Another use of the transformer is the single-phase transformer with several taps in the secondary. With this type of transformer, we can lower the voltage and also have several working voltages, as shown in figure 24. A center-tapped transformer powering a motor requiring 220 volts, along with for lights requiring 110 volts is shown in figure 25. The motor is connected across the entire transformer output, and the lights are connected from the center tap to one end of the transformer. With this connection we are using only half of the secondary output.

5-16. This type of transformer connection is used quite extensively because of the combinations of voltages that may be taken from one transformer. Various voltages may be picked off the secondary winding of the transformer by inserting taps (during manufacture) at various points along the secondary winding. The various amounts of voltage are obtained by connecting to any two taps or to one tap and either end, as shown a previous illustration.

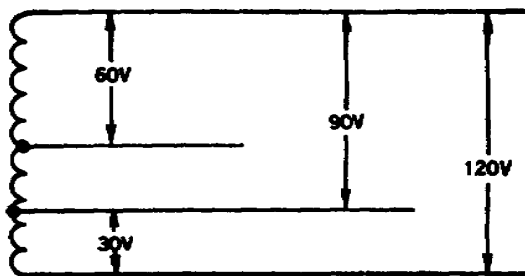

Figure 24. Multivoltage transformer secondary.

5-17. Transformers for three-phase circuit can be connected in any one of several combinations of the wye (γ) and delta (Δ) connections. The connection used depends on the requirements for the transformer.

5-18. *Wye connection.* When the wye connection is used in three-phase transformers, a fourth or neutral wire may be used, as show in figure 26. The neutral wire serves to connect single-phase equipment to the transformer. Voltages (120 v) between any one of the three-phase lines and the neutral wire can be used for power for devices such as lights or single-phase motors. Single- and three-phase equipment can be operated simultaneously, as show in figure 27.

5-19. In combination, all four wires can furnish power at 208 volts, single and three-phase, for operating single- and three-phase equipment such as motors or rectifiers with the center tap used as equipment ground. When only three-phase equipment is used, the ground wire may be omitted. This leaves a three-phase, three-wire system.

5-20. *Delta connection.* Figure 28 shows the primary and secondary with a delta connection. Between any two phases the voltage is 240 volts. This type of connection using the three wires - A, B, and C - can furnish 240-volt, three-phase power for the operation of three-phase equipment.

5-21. *Wye and delta connections.* The type of connection used for the primary coils may or may not be the same as the type of connection used

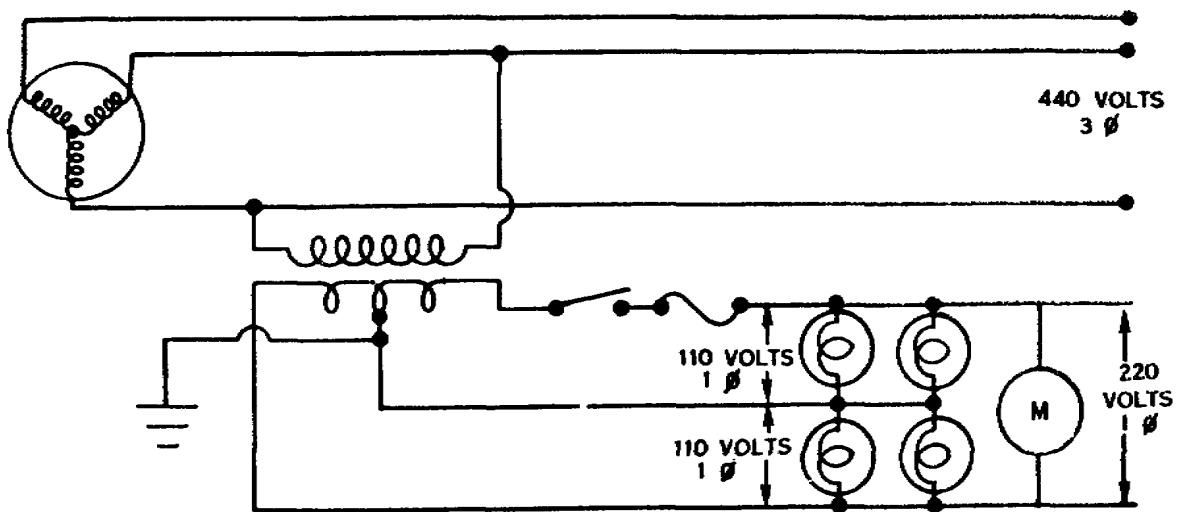

Figure 25. Step-down transformer, three-wire system.

for the secondary coils. For example, the primary may be a delta connection and the secondary a wye connection. This is called a delta-wye (Δ -y) connected transformer. Other combinations are delta-delta, wye-delta, and wye-wye.

5-22. **Current Transformers.** Current transformers are used in ac power supply systems.

5-23. The current transformer is a ring type transformer using a current-carrying power lead as a primary (either the power lead or the ground lead of the ac generator). The current in the primary induces a current in the secondary by magnetic induction.

5-24. The sides of all current transformer are marked "H1" and "H2" on the unit base. The transformers must be installed with the "H1" side toward the generator in the circuit in order to have proper polarity. The secondary of

the transformer should never be left open while the system is being operated; to do so could cause dangerously high voltages and could overheat the transformer. Therefore the transformer output connections should always be connected with a jumper when the transformer is not being used but is left in the system.

6. Electrical Meters

6-1. In the installation, inspection, maintenance, and operation of electrical air-conditioning equipment, you will often have to measure voltage, current, and resistance. A number of instruments have been developed for this purpose.

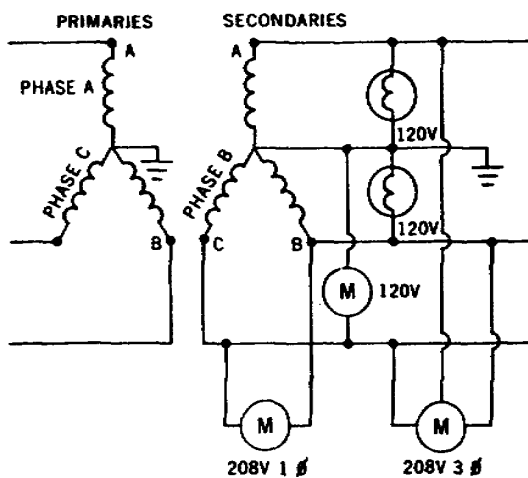

Figure 28. Wye-to-wye connection.

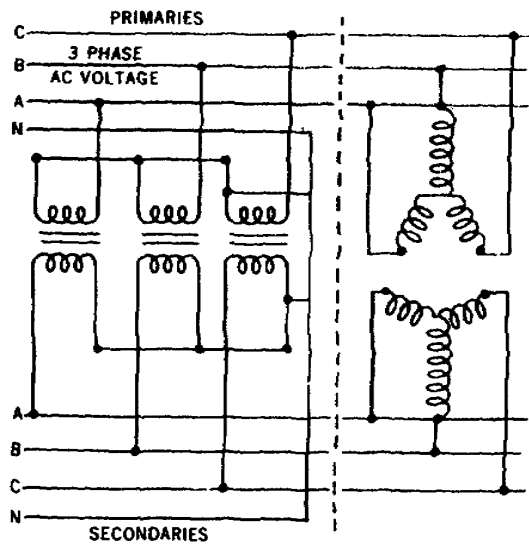

Figure 2. Four-wire, three-phase wye system.

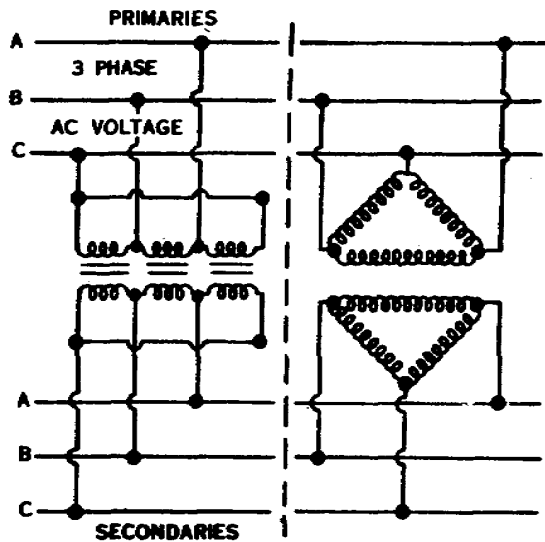

Figure 28. Delta-to-delta connection.

We will discuss these meters and their uses.

6-2. **Galvanometer.** In electrical systems the moving-coil galvanometer (D'Arsonval type) is used quite extensively. This movement is used in such instruments as voltmeters, ammeters, thermocouple thermometers, and electrical tachometer.

6-3. **Voltmeter.** A voltmeter is an instrument used to measure the difference in electrical potential, or the voltage, between two point. (See fig. 29.) Notice in figure 29 the rotary switch which may be connected to various size resistors. These are in series with the movable coil to limit the amount of current flow through

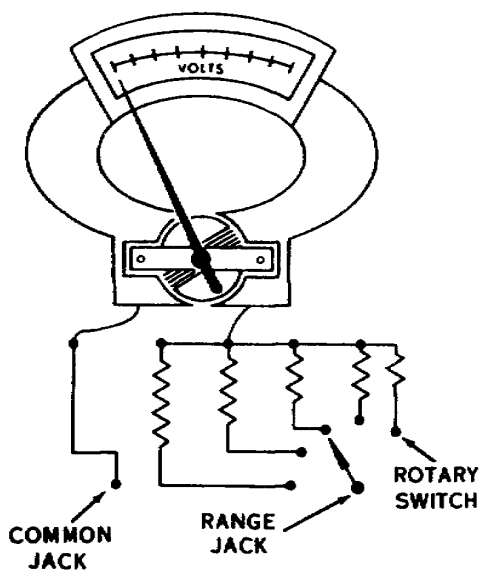

Figure 29. Voltmeter.

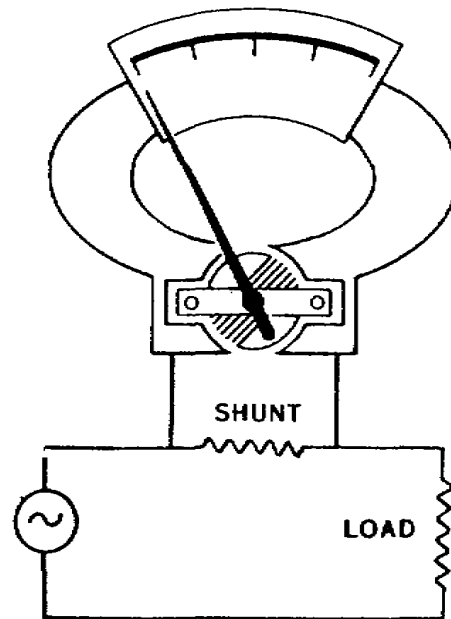

Figure 30. Ammeter with an external shunt.

the meter circuit. If an unmarked voltage is to be measured, set the rotary switch to the highest resistance and work down until the meter reads in a somewhat mid-position of full scale.

6-4. **Ammeter.** An ammeter is an instrument that measures the amount of current flowing in a circuit. You may have a need for an ammeter with a range from a milliampere to 500 amperes. These meters may have an external shunt, as shown in figure 30, or they may be internally shunted. Question: What is a shunt for? Answer: Very fine wire is used in the coil. This wire can carry very little current without overheating - only a small fraction of an ampere. A low-resistance shunt is connected in parallel with the meter so that most of the current bypasses the meter; only a very small portion of the total current flows through the coil. For example: When a 300-ampere ammeter and a 300-ampere shunt are connected into a circuit carrying 300 amperes, only 0.01 ampere flows through the meter to give full-scale deflection; the remaining 299.99 amperes flow through the shunt.

6-5. By applying the basic rule for parallel circuits, you can easily compute the value of a shunt resistor needed to extend the range of an ammeter.

6-6. **Ohmmeter.** An ohmmeter is an instrument used to measure resistance in ohms. Combination volt-ohmmeters and other multipurpose meters are used more than simple ohmmeters. The principle of operation of an ohmmeter is

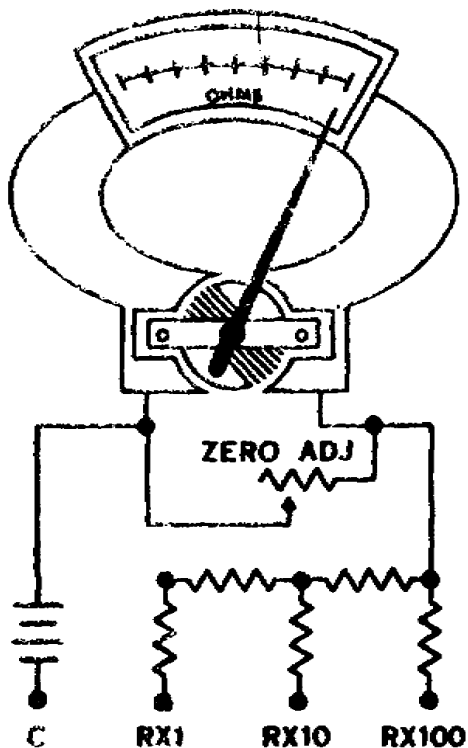

Figure 31. Ohmmeter.

basically the same, regardless of whether the meter is a separate instrument or is part of a multipurpose instrument.

6-7. An ohmmeter contains a very sensitive galvanometer. The scale on the dial is calibrated in ohms. Maximum current flows through the circuit when there is a minimum amount of resistance between the ohmmeter terminals. For this reason, zero is at the right-hand end of the scale. The ohmmeter does not have an evenly graduated scale; frequently the right half of the scale will read to about 5000 ohms, while the left half will read 100,000 ohms or more. The left-hand end of the scale is sometimes marked "INF," which means there is infinite resistance between the terminals.

6-8. Some ohmmeters have three or even four posts to which the leads may be attached. (See fig. 31.) These posts may be marked in different ways on different meters, but for purposes of explanation let us consider a meter on which the posts are marked "C," "RX1," "RX10," and "RX100." If the leads are connected to C and RX1, the resistance being measured is indicated directly on the scale. If the terminals are connected to C and RX10, the reading on the scale must be multiplied by 10 to give the actual resistance. If the terminals are connected to C and RX100, the reading on the scale must be multiplied by 100. Short the two leads together

and zero the meter with the zero adjustment. This must be done any time the lead is moved from one jack to another.

CAUTION: Make sure the circuit to be measured is dead before using the ohmmeter.

6-9. **Rectifier Meter.** Alternating-current voltages are often measured by rectifier type meters. A rectifier meter is actually a dc meter with a rectifier added to change the ac to dc. Without a rectifier, of course, a dc meter would give no indication when applied to an ac circuit. Generally, a copper-oxide rectifier connected as a bridge provides the rectification. This is shown in figure 32. Values of ac voltages indicated on the rectifier meter are effective values.

6-10. **Wattmeters.** Power in an ac circuit is not always found by multiplying voltage by amperage as in a dc circuit. Such a power computation can be made for ac circuit only when the voltage and current are in phase, that is, when there is a purely resistive load. In practice this condition seldom exists, since in almost all ac circuits the load is reactive because of the presence of inductance and capacitance. The wattmeter, however, measures the true power consumed in a circuit by all electrical devices regardless of the type of load.

6-11. Wattmeters may be used to measure power consumed in either single-phase or three-phase circuits in which the load is balanced. The single-phase wattmeter has a high-resistance moving voltage coil for many turns of fine wire and stationary coils, called current coils, of low resistance with a few turns of heavy wire. Connect the current coils in the line in series with the load, and the voltage coil across the line.

6-12. A single-phase wattmeter may be connected to measure the power by a three-phase circuit. To do this, connect the current coil in one load line and the voltage coil between the line and ground. This will give the power in one phase. Multiply this by 3 to get the total power.

6-13. Three-phase wattmeters consist of two or more single-phase movement with all the moving elements mounted on one shaft. Separate single-phase wattmeters can be used to measure power in three-phase circuits by connecting two wattmeter in any two of the three phases. In this case, add the two wattmeter readings if the power factor of the load (motor) is greater than 50 percent (the power factor can be found on the nameplate or in the technical order). If the power factor is below 50 percent, the power input to the load (motor) is the difference between the two readings.

6-14. You can determine whether to add or subtract the readings by the following: If both of the scale pointers deflect toward the top of the scale, add the readings; if one tends to indicate a negative value, reverse either the voltage or

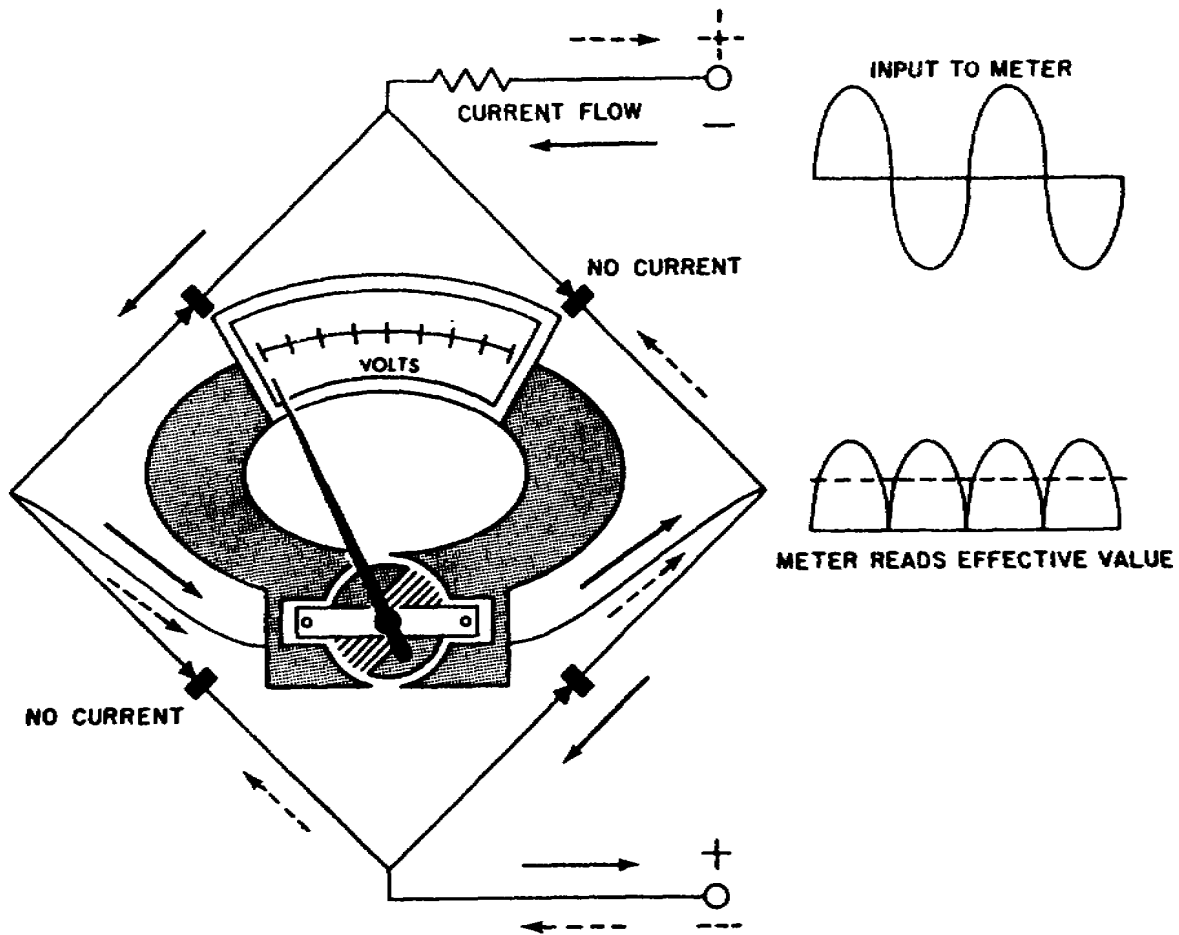

Figure 32. Rectifier meter circuit.

current connections and subtract the reading of one wattmeter from the reading of the other.

6-15. **Using Electrical Meters.** Only two of the meters discussed in this chapter, the voltmeter and the ohmmeter, are used to locate troubles in an electrical circuit. How the meters are used for this purpose will be explained in detail. However, before attempting to use any of the meters which have been discussed, you should fix firmly in your mind certain precautions concerning their use.

6-16. *General precautions.*

(1) Never connect a voltmeter to a circuit having a voltage that exceeds the voltmeter scale. If the voltage is unknown, start with a high scale and work down until you get the correct one.

(2) Never connect an ammeter into a circuit carrying more current than the maximum reading on the scale of the meter.

(3) Always connect an ammeter in series with the units in the circuit.

(4) Never connect an ammeter across the terminals

of a battery or generator, or any other place where you provide a path through the meter from a source of voltage direct to ground. To do so would cause the meter to burn out immediately.

(5) Always check the rating of a meter before you use it.

(6) Never use an ohmmeter to check an electrical circuit until the source of voltage has been disconnected from all parts of the circuit to be checked. Using the ohmmeter in a live circuit would damage the meter.

(7) Always connect the voltage coil of a wattmeter to the supply side of the current coil.

6-17. *Voltmeter.* The most common trouble found in electrical circuits that are inoperative is an open circuit. This means simply that there is not a complete path for the current to flow through as it should. The "open," or the place where the circuit is open, can be located with either a voltmeter or an ohmmeter. If electrical power is available, use the voltmeter.

6-18. An open in a circuit may be located anywhere in the circuit. It may be in the switch,

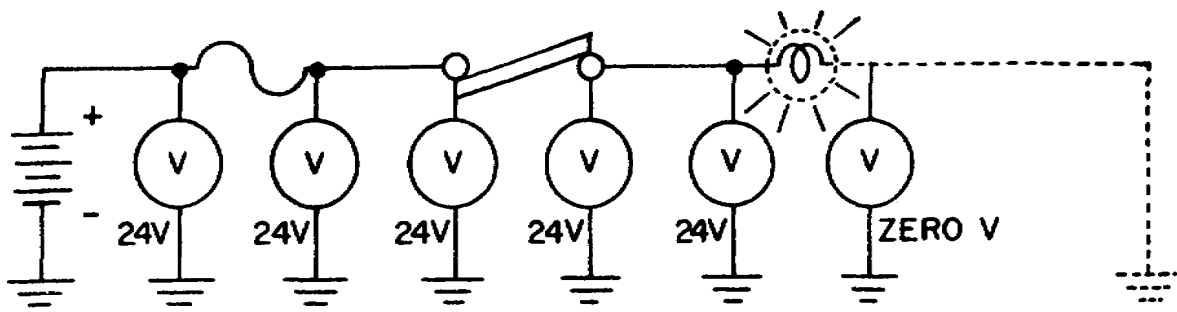

LAMP ON NORMAL READINGS

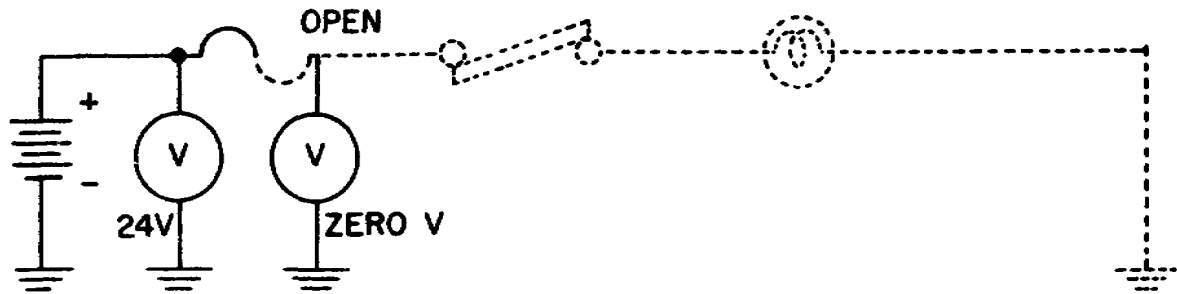

LAMP OUT—OPEN IN FUSE

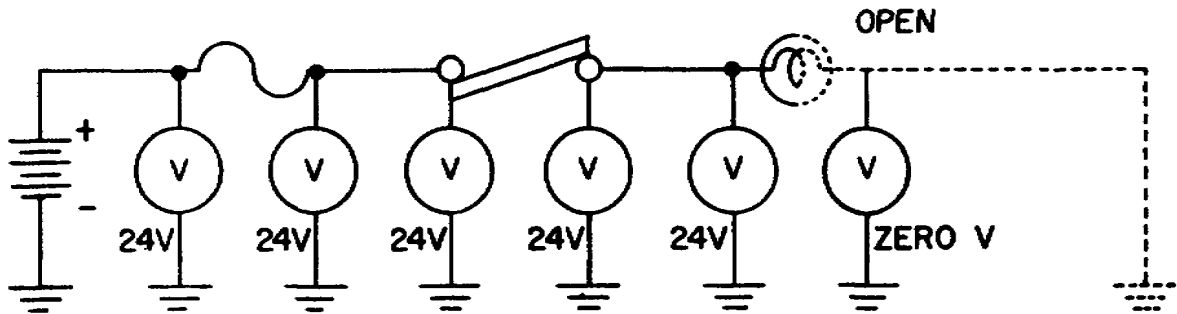

LAMP OUT—OPEN IN LAMP

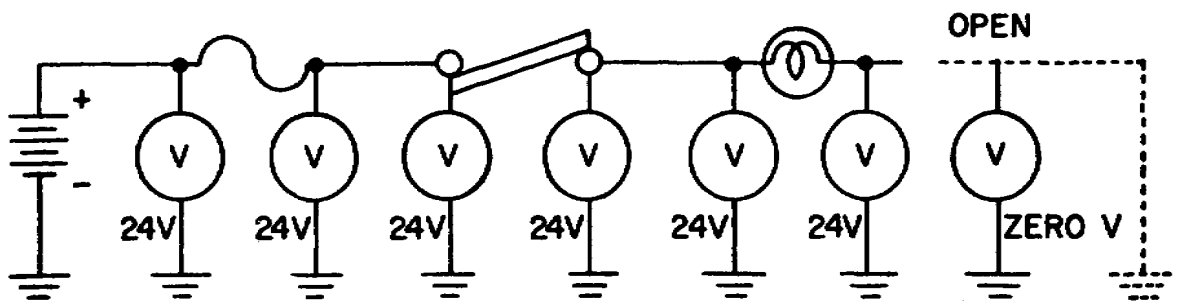

LAMP OUT—OPEN IN GROUND CONNECTION

Figure 33. Continuity testing with a voltmeter.

fuse, wiring, or in the unit itself. If the fuse is burned out, or open, you should inspect all of the circuit to determine what caused the fuse to blow.

6-19. A trouble known as a *short* might have caused the fuse to blow. A short is direct contact between the hot and negative or ground portion of the circuit. Since there is practically no resistance in this new or *short* circuit, the current flow increases immediately until it exceeds the capacity of the fuse and blows the fuse.

6-20. A voltmeter is always connected in parallel with the unit being tested - that is, across the unit - or to the points between which the difference of potential is to be measured.

6-21. If you should accidentally connect the voltmeter in series with the circuit, it wouldn't hurt the meter because the high resistance in the meter would limit the current flow. However, the units in the circuit would not operate because of the low current.

6-22. Locating an open with a voltmeter is simply a matter of checking to see how far voltage is present in the circuit. Voltage will be present the circuit right up to the point where the circuit is open.

6-23. When you have to check a circuit to find an open, you can start at any point in the circuit. It is logical, of course, to check the fuse first and the unit second. As explained earlier, this will enable you to tell whether the trouble is an open or a short.

6-24. If the fuse and the unit are both good, you may have to check each end of each length of wire in the circuit to find the open. Use the wiring diagram of the circuit as a guide. The important things are to know what voltage reading you should have at each point in the circuit and to recognize an abnormal reading when you get one. Figure 33 shows the voltage readings obtained at different points in a circuit with an open fuse, an open lamp filament, and one with an open ground wire.

6-25. *Ohmmeter.* Before you use an ohmmeter to check a circuit, be sure there is no electrical power in the circuit. It was explained earlier in this chapter that using an ohmmeter in a live circuit could damage the meter.

6-26. If you use a multirange ohmmeter to check resistance, choose a scale on the ohmmeter which you think will contain the resistance of the element you are going to measure. In general, select a scale in which the reading will fall in the mid-scale range. Short the leads together and set the meter, with the zero adjustment, to read zero ohms. If for any reason you change scales, readjust the meter to zero ohms.

6-27. Connect the leads across the circuit. Infinite resistance indicates an open circuit. A reading other than infinite resistance indicates continuity.

6-28. Let's simulate locating the troubles with the ohmmeter. First we must be sure we have disconnected

the power from the circuit to permit use of the ohmmeter. Now, with one lead connected to negative or ground, check at various points with the other lead. If you start at the point where the circuit is grounded, the meter will read zero ohms.

6-29. After you pass the first resistance the meter will read that resistance. When you get the first reading of infinite resistance, this will indicate that the open is between that point and the point where you got the last normal reading.

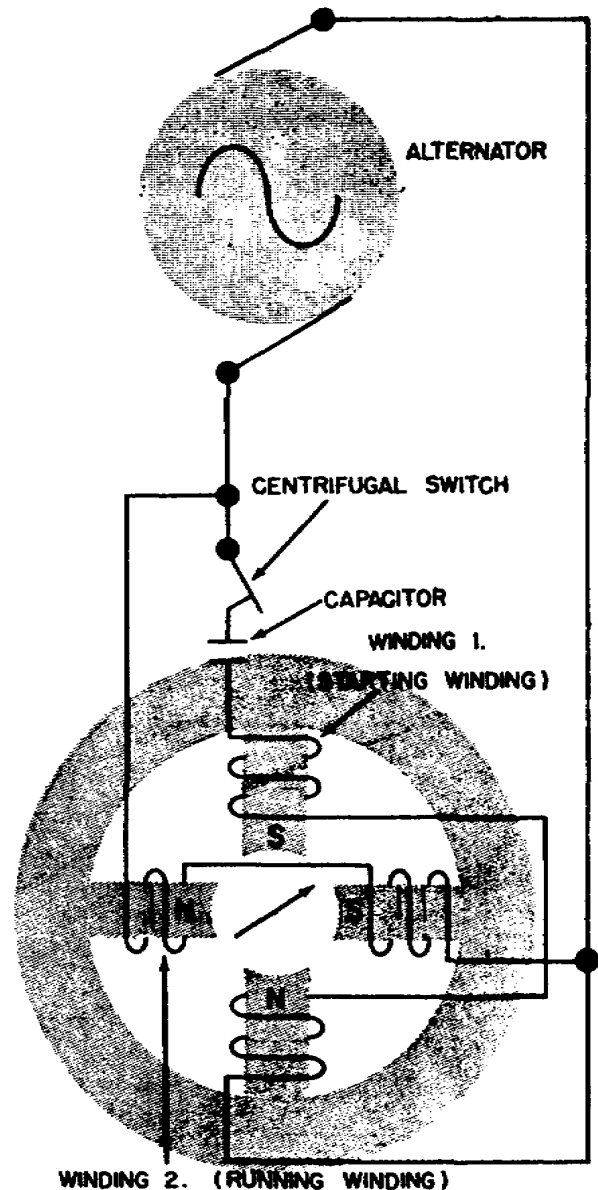

Figure 34. Single-phase motor with capacitor starting winding.

6-30. When you check continuity in a parallel circuit, isolate the unit you are checking so the ohmmeter will not show the resistance of parallel paths.

7. Motors

7-1. In this section we will discuss some of the electrical motors that you may encounter in your job. We will discuss ac single and polyphase induction motors, ac/dc universal motors, and synchronous motors.

7-2. **Principles of Operation.** The speed of rotation of an ac motor depends upon the number of poles and the frequency of the electrical source of power:

$$\text{Rpm} = \frac{120 \times \text{frequency}}{\text{number of poles}}$$

7-3. Since an electrical system operates at 60 cycles, an electric motor at this frequency operates about 2 1/2 times the speed of the old 25-cycle motor with the same number of poles. Because of this high speed of rotation, 60-cycle ac motors are suitable for operating larger refrigeration systems.

7-4. Alternating-current motors are rated in horsepower output, operating voltage, full-load current, speed, number of phases, frequency, and whether they operate continuously or intermittently.

7-5. **Single-Phase Induction Motors.** All single-phase induction motors have a starting winding (see fig. 34) since they cannot be started with only the single-phase winding on the stator. After the motor has started, this winding may be left in the circuit or be disconnected by a centrifugal switch.

7-6. Both single-phase and three-phase motors operate on the principle of a rotating magnetic field. As a simple example of the principle

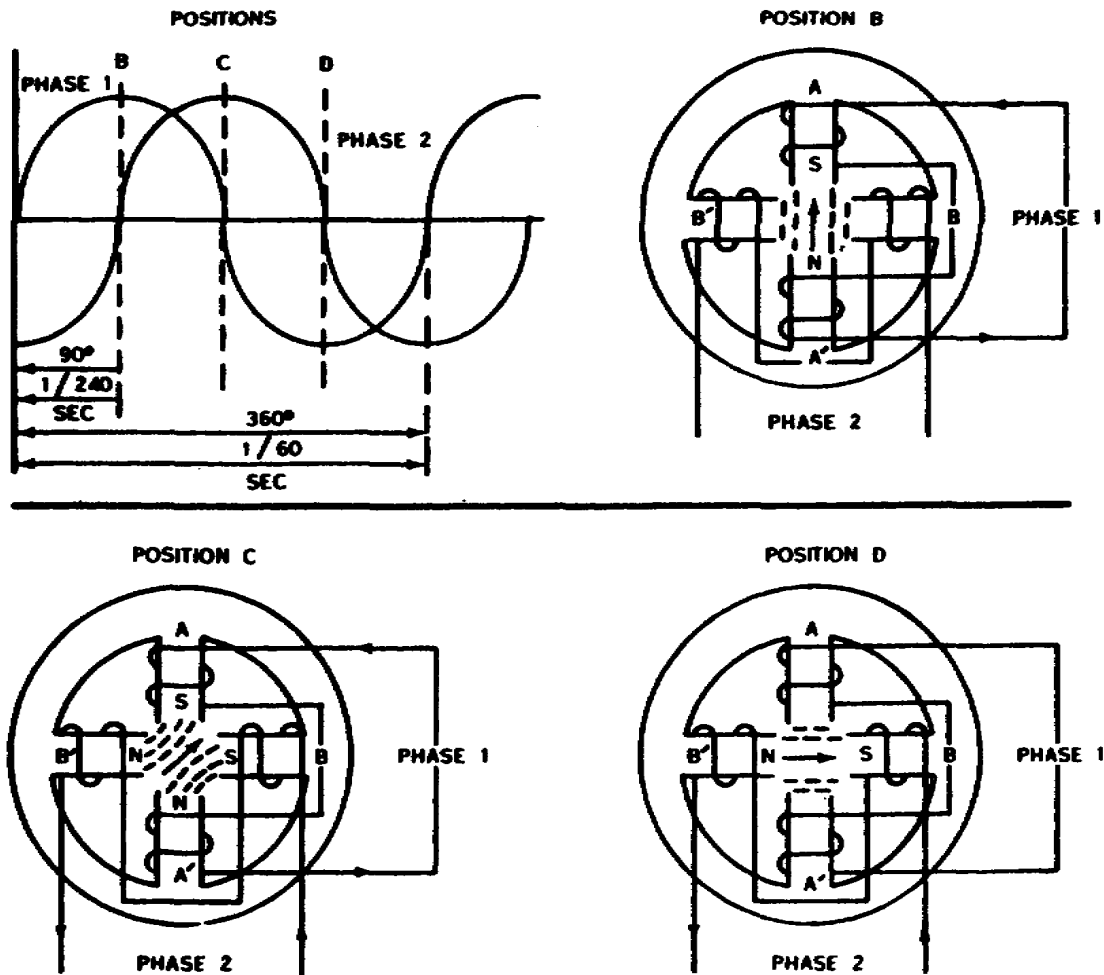

Figure 35. Production of a rotating magnetic field.

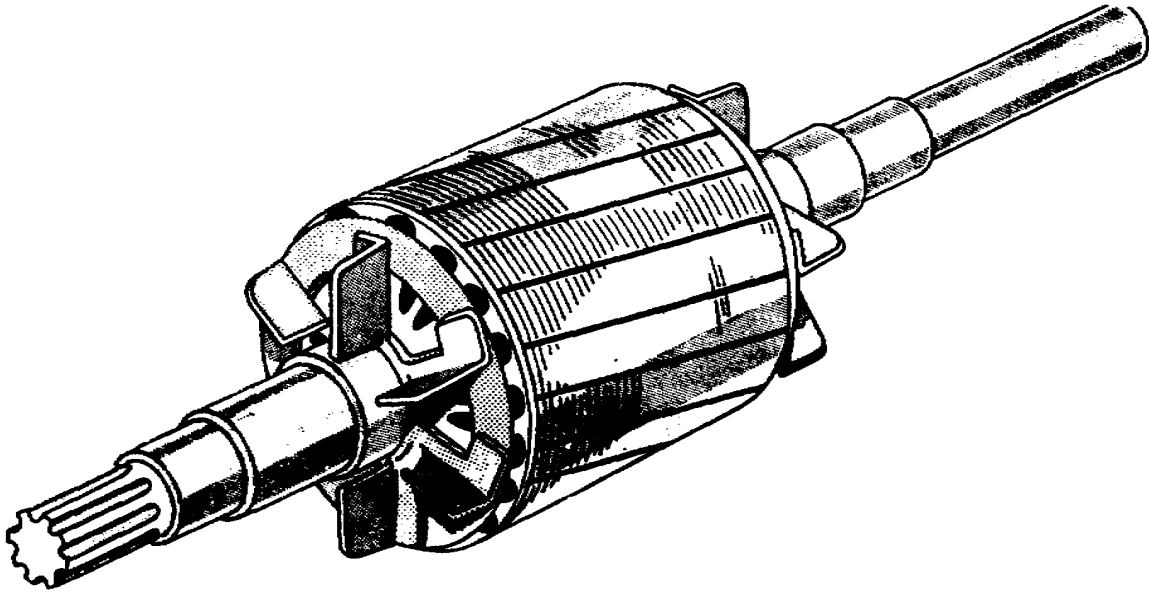

Figure 36. Squirrel-cage induction-motor rotor.

of the rotating field, imagine a horseshoe magnet held over a compass needle. The needle will take a position parallel to the magnetic flux passing between the two poles of the magnet. If the magnet is rotated, the compass needle will follow.

7-7. A rotating magnetic field can be produced by a two- or three-phase current flowing through two or more groups of coils wound on inwardly projecting poles of an iron yoke. The coils on each group of poles are wound alternately in opposite directions to produce opposite polarity, and each group is connected to a separate phase of voltage.

7-8. You can understand this action with the aid of figure 35, which shows a four-pole stator field energized by two windings connected to two separate phase voltage. Winding No. 1 of the motor is 90° out of phase with winding No. 2, which causes the current in winding No. 1 to lead the current in winding No. 2 by 90° , or by $1/240$ second, assuming the frequency of the ac power supply is 60 cycles per second. Winding No. 1 can be referred to as phase 1, and winding No. 2 as phase 2.

7-9. The direction of the magnetic field is indicated by a magnetic needle (considered as a north pole for clarity). The needle will always move to a position where it will line up with the magnetic flux passing from pole to pole. Notice the phase relationship of the two voltages which are applied to the two phase windings of the field. Phase 1 supplies current to the coils on poles A and A', and phase 2 supplies current to the coils on poles B and

B'. The two currents are 90° out of phase, with phase 1 leading.

7-10. At position B, the current in phase 1 at a maximum and the poles of A and A' are fully magnetized. The poles of coils B and B' are not magnetized, since the current in phase 2 is zero. Therefore the magnetic needle points in the direction shown. At position C, the current coils A and A', phase 1, has decreased to the same value to which the current in coils B and B', phase 2, has increased. Since the four poles are now equally magnetized, the strength of the field is concentrated midway between the poles, and the magnetic needle take the position shown.

7-11. At position D, the current of phase 1 is zero through coils A and A', and there is no magnetism in these coils. There is maximum current through coils B and B', the magnetic field strength of B and B' is maximum, and the magnetic needle takes the crosswise position. This action is repeated during successive cycles of the flow of the alternating currents, and the magnetic needle continues to revolve in the same direction within the field frame as long as the two phase currents are supplied to the two sets of coils.

7-12. In an induction motor with two poles for each phase winding, the north pole would glide from one pole to the other in $1/120$ second and make a complete revolution in $1/60$ second, which would be at the rate of 3600 rpm. If the compass needle is replaced by an iron rotor wound with copper bar conductors (usually

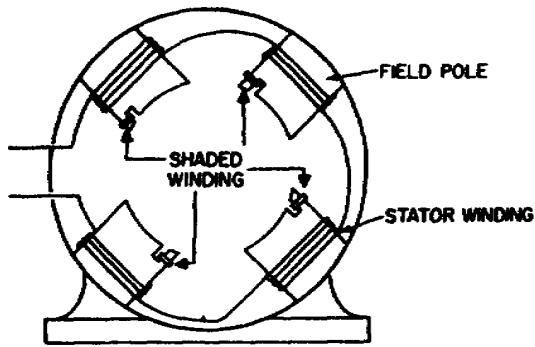

Figure 37. Shaded pole motor stator windings.

called a squirrel-cage rotor because the conductors resemble a squirrel cage, as shown in figure 36, a secondary voltage is induced in the conductors by mutual induction much in the manner that the secondary voltage is developed in a transformer.

7-13. Current flowing in the conductors produces a magnetic field which reacts on the rotating magnetic field and causes a rotation of the iron core similar to the rotation of the magnetic needle. The direction of rotation may be reversed by reversing the connections of one phase.

7-14. *Shaded-pole motor.* The stator windings of a shaded-pole motor differ from other single-phase motors by definitely projecting field poles (fig. 37). A low-resistance, short-circuited winding or copper band is placed across one tip of each pole, from which the name "shaded-pole" is derived. As the current increases in the stator winding, the flux increases. A portion of this flux cuts and induces a current in the shaded winding. This current sets up a flux which opposes the flux inducing the current; therefore, most of the flux passes through the unshaded portion of the pole, as shown in figure 38.

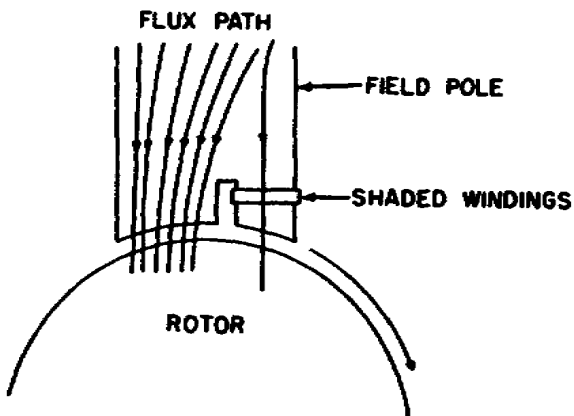

Figure 38. Flux path in a shaded-pole motor.

When the current in the winding and the main field flux reaches a maximum, the rate of change is zero, so no electromotive force is induced in the shaded winding. A little later the shaded winding current, which lags the induced electromotive force, reaches zero, and there is no opposing flux. Therefore the main field flux passes through the shaded portion of the field pole. This results in a weak rotating magnetic field with sufficient torque to start small motors. Because of the low starting torque, shaded-pole motors are furnished in ratings up to approximately 1/25 horsepower and are used with small fans, timing relays, small motion picture projectors, and various control devices. Shaded-pole motors are designed for a specific direction of rotation that cannot be changed after the motor is assembled.

7-15. *Split-phase motor.* Split-phase motors contain two windings, the main winding and the starting winding. The main winding is wound on the stator and the starting winding is wound on top of the main winding in such a

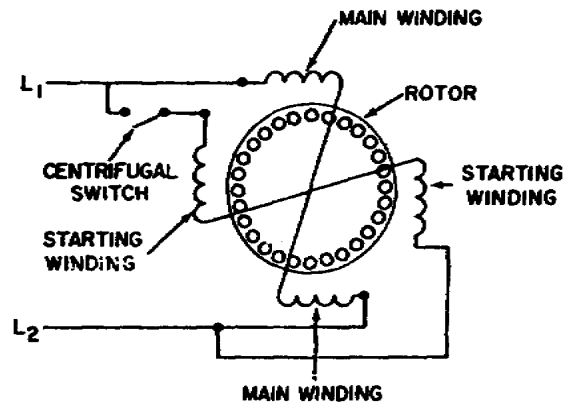

Figure 39. Schematic of a single-phase, split-phase motor.

manner that the centers of the poles of the two windings are displaced by 90°. The windings are connected in parallel (fig. 39) to the same supply voltage; therefore, the same voltage is applied to both winding. The starting winding is usually wound with fewer turns of small size wire and has iron on only two sides. It, therefore, has less inductance than the main winding, which has a low resistance and is surrounded by iron on all sides except one. When the same voltage is applied to both windings, the current in the main winding lags the voltage more than the current in the starting winding. This produces a rotating field which starts the motor. As the motor approaches full speed, a centrifugal mechanism mounted on the rotor opens a centrifugal switch (fig. 39) and disconnects the starting winding from the line. If the centrifugal mechanism should fail to open the switch, the motor will run hot because of the high resistance of the starting winding and will burn

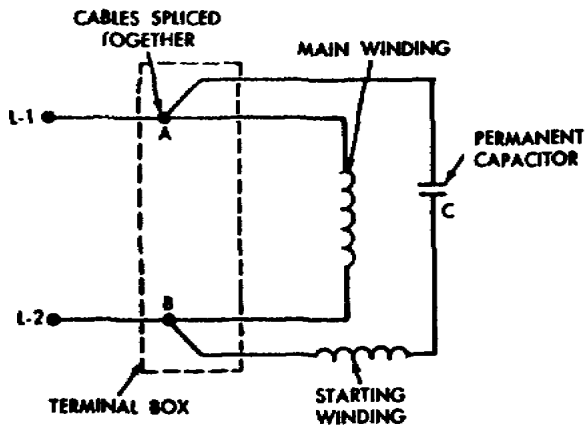

Figure 40. Schematic of a single-phase permanent-split capacitor motor.

out the starting winding if allowed to run any length of time. This is the most frequent cause for failure of split-phase motors. The split-phase motors are usually furnished in ratings from 1/60 to 1/3 horsepower and are desirable for use in machine tools, office equipment, pumps, fans, blowers, oil burners, kitchen appliances, and laundry equipment. Split-phase motors may or may not have a built-in thermal overload relay for the protection of the motor during an overload. The relay is usually of the automatic type, opening when the current in the windings is above normal and automatically resetting when the current is restored to normal. To reverse the split-phase motor, reverse the loads of either the starting winding or the running winding.

7-16. *Capacitor-start motor.* The capacitor-start

motor is so called because a capacitor instead of resistance is used to split the phase. The capacitor, usually mounted on top of the motor, is connected in series with the starting winding to provide the necessary shift in time phase of the current flowing through it. This capacitor is usually intermittently rated and must be disconnected for normal operation, which disconnection is usually done by a centrifugal mechanism mounted on the rotor. When the motor is stopped, the switch closes and is in the correct position when the motor is started again. The capacitor-type motor has a higher starting torque at less current than the split-phase motor and also provides a greater thermal capacity. Capacitor-start motors are usually furnished in ratings from 1/6 to 1 horsepower and are used on compressors, pumps, fans, and machine tools.

7-17. *Permanent-split capacitor motor.* The permanent-split capacitor motor is similar to the capacitor-start motor, except that the permanent capacitor (fig. 40) is connected in series with the starting winding permanently and is not removed from the circuit during operation by a centrifugal switch. This eliminates the need for a centrifugal switch and switch mechanism. The capacitor is continuously rated and is selected to give best operation at full speed while sacrificing starting torque. Permanent-split-capacitor motors develop 40 to 60 percent starting torque and are used on easily started loads such as fans and blowers.

7-18. *Capacitor-run motor.* The capacitor-run motor has two capacitors connected in parallel (fig. 41). One, a running capacitor, is a continuously rated capacitor and remains in the

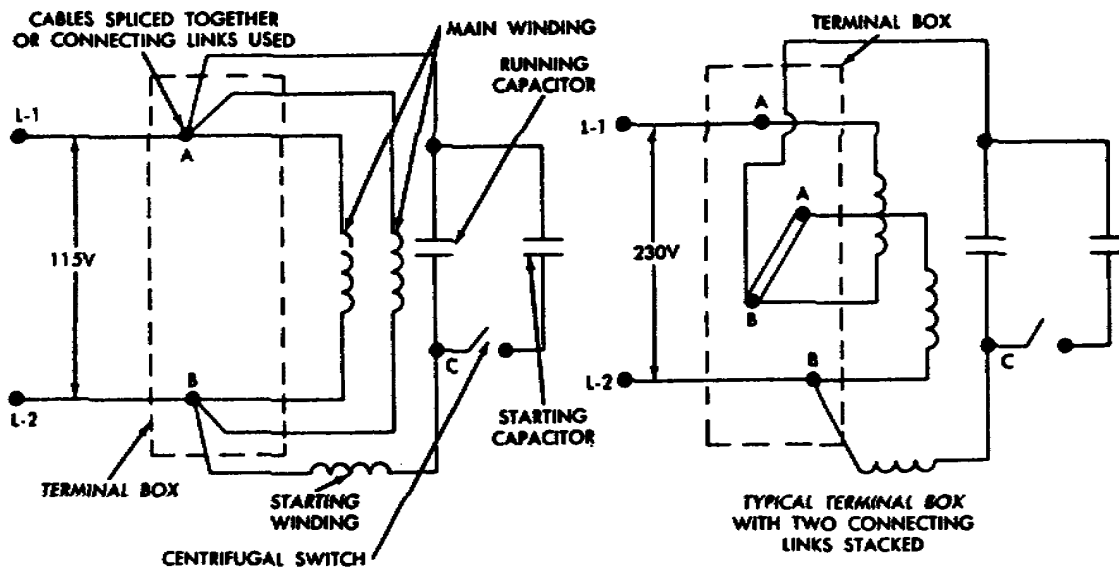

Figure 41. Schematic of a single-phase dual voltage capacitor run motor.

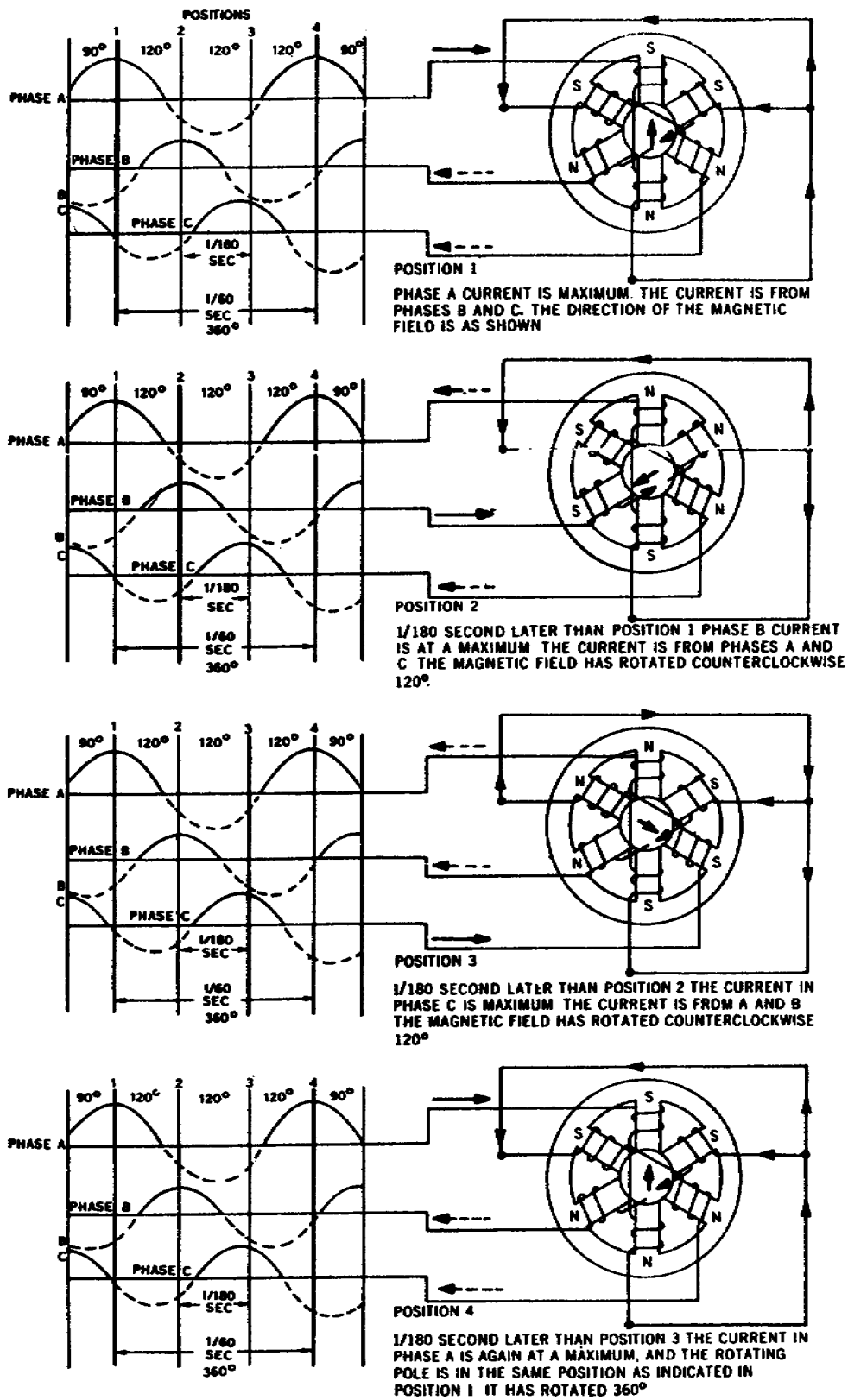

Figure 42. Three-phase induction motor.

circuit while the motor is running. The other, a starting capacitor, is intermittently rated and is used in the circuit during starting. The starting capacitor is removed by a centrifugal mechanism and switch as the motor approaches full speed. Therefore the capacitor-run motor is a combination of the capacitor-start and the permanent-split capacitor motors. This motor has a high starting torque as well as good running characteristics and is generally furnished in ratings of 1/2 horsepower and larger. Capacitor motors may be reversed by changing the leads to the starting winding at the motor terminals.

7-19. **Three-Phase AC Induction Motors.** The three-phase ac induction motor is also called a squirrel-cage motor. The rotating magnetic field of the three-phase motor operates the same as a two-phase motor. The difference between a two-phase and a three-phase motor in the windings. The two-phase windings are placed 90° apart where the three-phase windings are placed 120° apart. This means that the currents that produce the magnetic field reach a maximum 1/180 second apart in a 60-cycle circuit.

7-20. Notice figure 42, which shows the connection of a wye-connected stator in a three-phase induction motor. The rotor of the motor is represented by the compass needle, which points in the direction of the magnetic field and revolves as the magnetic field revolves. The individual current waves are shown along the phase wires as they would actually be during operation. Notice the current in phase A reaches a maximum at position 1 and at that instant the currents in phases B and C are both negative.

7-21. At position 2, 1/180 second later, the current is at a maximum in phase B and is negative in phases A and C. At position 3, which is 1/180 second later than

position 2, the current is at positive maximum in phase C and is negative in phases A and B. In the diagrams the magnetic field caused by the maximum positive current is shown in heavy dark lines. The other poles are indicated with dotted lines. The rotor, like the single-phase motor, follows the rotating magnetic field of the stator winding.

7-22. The speed of the induction motor is always less than the speed of the rotating field of the stator. If the rotor were to turn at the same speed as the rotating field, the rotor conductors would not be cut by any magnetic field and no voltage would be induced in them. No current would flow; thus there would be no magnetic field in the rotor and, hence, no torque.

7-23. A three-phase induction motor exerts a torque when at rest and therefore starts itself when the proper voltage is applied to the stator field coil. To reverse the direction of rotation of a three-phase motor, reverse the leads of any two phases.

7-24. The three-phase spring (wound rotor) induction motor is wound with a three-phase drum winding. The windings are connected wye (y) or delta (wye connection is shown in fig. 43), and the three leads are brought out and connected to three electrical contact rings (sliprings) which are secured to the shaft. Brushes riding on the rings are connected to an external resistance through which the rotor circuit is completed. Motors containing wound rotors have a high starting torque with low starting current us adjustable speed.

7-25. **Synchronous Motors.** Synchronous motors are divided into two classes according to their size and application. The larger horsepower motors use three-phase power and have separately excited salient pole rotors. The smaller motors are usually furnished as fractional-horse-

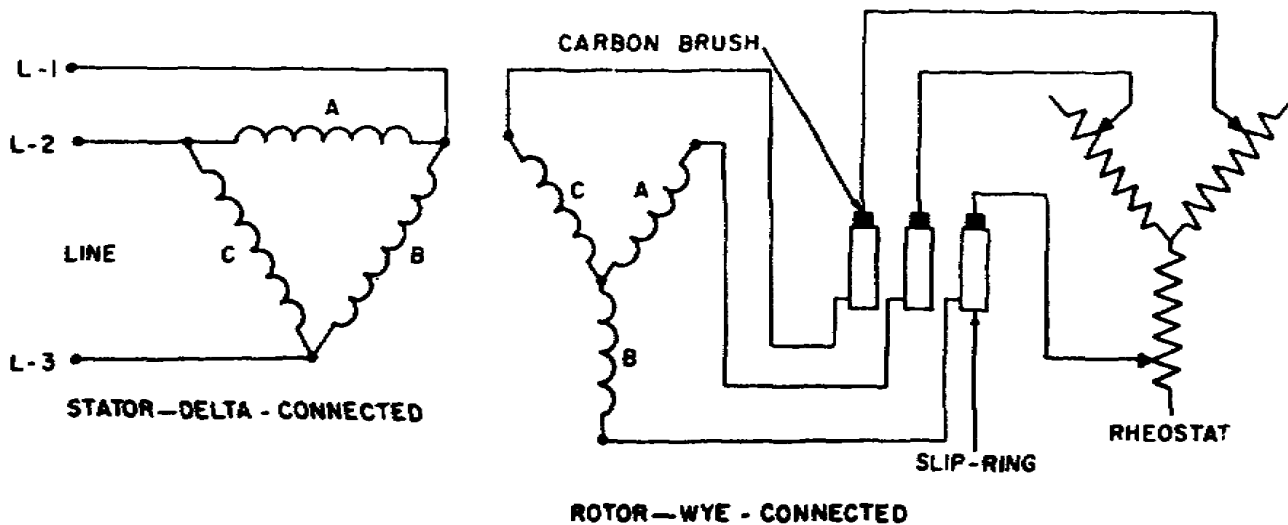

Figure 43. Schematic of a three-phase slipring induction motor.

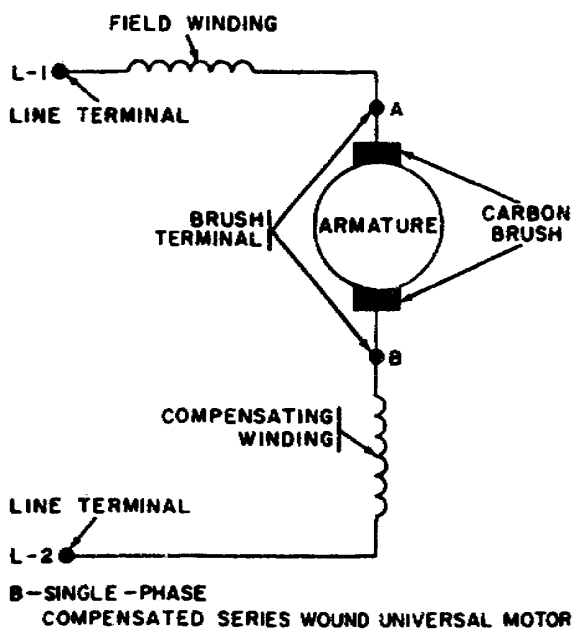
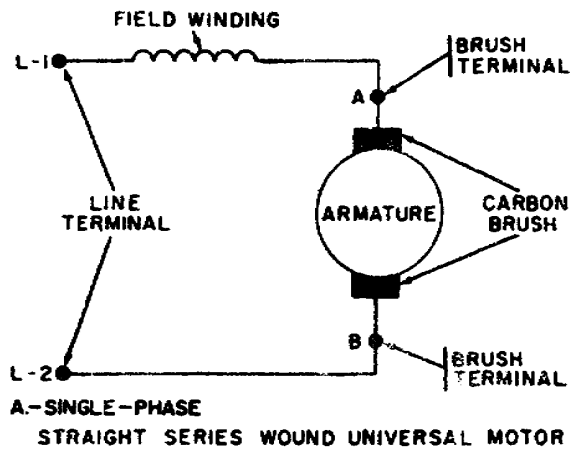

Figure 44. Schematic wiring diagrams of universal motors.

power motors and obtain their rotor-excitation current through induction. Although an induction motor is considered as a constant-speed motor, it is subject to approximately 10 percent variation in speed under various load conditions, since the operating torque depends upon the percentage of slip between the rotating magnetic poles and the magnetic flux of the rotor. The speed of a synchronous motor is controlled by the frequency of the alternating-current power source and is, therefore, maintained with a high degree of accuracy. The smaller

size synchronous motors are constructed as reluctance motors or hysteresis motors, which are described in following paragraphs.

7-26. *Reluctance motor.* The stator of a reluctance motor is similar in construction to that of the single-phase induction motor and may be of the shaded-pole, split-phase, or capacitor type. The squirrel-cage rotors have grooves cut to allow the addition of salient poles. The number of salient poles mounted on the rotor corresponds to the number of rotating stator poles. The motor starts as an induction motor, but, upon reaching a speed near synchronism, it pulls into step because of the salient poles and operates at exactly synchronous speed. The reluctance motor, unlike the larger size synchronous motor (which has on the rotor a field winding supplied with direct-current excitation and which operates at unity or at a leading power factor with high efficiency), operates at a lagging power factor and has a rather low efficiency. Therefore, the reluctance motor is used only where exact synchronous speed is required, such as in electric clocks, time switches, relays, and meters.

7-27. *Hysteresis motor.* The construction of the hysteresis motor is similar to that of the reluctance motor except for the rotor. The rotor does not have a squirrel-cage winding. Instead the rotor core is usually made of a ring of metal having permeability, such as chrome or cobalt steel. The highly magnetic core material retains its magnetism over a period of time and this enables the rotor to reach its synchronous speed. Hysteresis motors develop a constant torque from zero synchronous speed and are used in a clock's timing devices; they will operate unattended for long periods of time.

7-28 **Universal Motors.** Universal motors are designed for operation from either direct current or single-phase alternating current and are all of the series-wound type; that is, the field windings are connected in series with the armature windings. Universal motors are divided into two types: the straight series-wound universal motor and the compensated series-wound universal motor.

7-29. *Straight series-wound universal motor.* The straight series-wound universal motor has the field windings connected in series for opposite polarity, the same as the field winding of any direct-current motor, and then in series with the armature (fig. 44A). This type motor uses salient-type pole pieces (fig. 45) for mounting the field windings and is usually furnished in sizes up to 1/3 horsepower but can be furnished in larger sizes for special applications. The motor full speed is rated from 1800 rpm on the larger sizes to 5000 rpm on the smaller sizes and no-load speeds ranging from 12,000 to 18,000 rpm. Since these motors run at dangerously high speeds at no-load, they are usually built into the

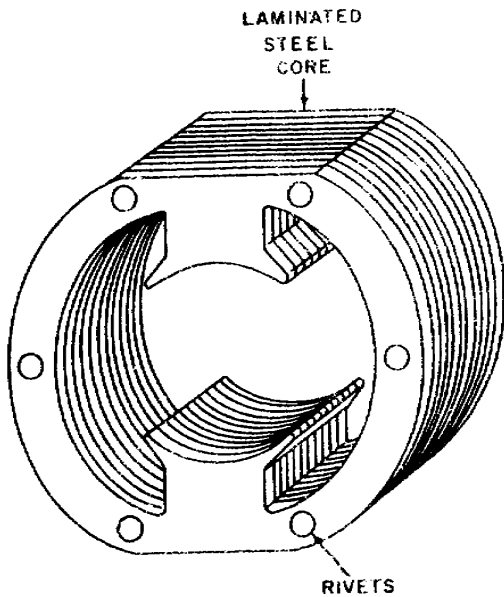

Figure 45. Salient pole laminated steel core of a universal motor.

equipment being driven. This type motor is used in portable machines and portable equipment in general.

7-30. *Compensated series-wound universal motor.* The compensated series-wound, distributed-field, universal motor contains a main winding and a compensating winding connected in series with the armature (fig. 44B). The core of this type motor is similar to the construction of the core of a split-phase alternating-current motor (fig. 46). The main winding is usually placed in the slots first and the compensating winding is placed over it, 90 electrical degrees away. The compensating winding reduces the reactance voltage present in the armature when alternating current is used. It has a better commutation and power factor than does the straight series-wound universal motor, and usually comes in higher horsepower ratings. Compensated series-wound universal motors are used with portable tools, office machines, vacuum-cleaning equipment, and portable equipment in general.

8. Motor Maintenance

8-1. Cleanliness is essential if we are to have trouble-free motor operation. Dirt, moisture, and excessive oil tend to restrict air circulation, deteriorate the insulation, and accelerate wear and friction. To increase the life of the motor, you should wipe all excessive dirt, oil, and grease from the surface of the motor. Use a cloth moistened with a recommended cleaning solvent.

CAUTION: Do not use flammable or toxic solvents for cleaning, as they may cause injury to personnel or damage to property.

8-2. The inside of the motor can be cleaned with a blower or with compressed air. Care should be exercised when using compressed air so the insulation is not damaged by the blast of air.

8-3. **Motor Lubrication.** You must be sure the motor has been properly lubricated. Lubrication should be done according to the applicable publication for the motor.

8-4. You should also make periodic checks for grease or oil leakage and for overlubrication. After lubricating a motor, be sure to wipe away any excess oil or grease.

8-5. **Wiring.** The wiring leads to the motor must be kept clean and secure and checked for wear. If the wiring becomes frayed, it must be replaced.

8-6. **Mounting.** Motors must be kept secure to perform efficiently. A loose mounting can cause a belt to slip and wear or can cause vibrations which tend to harden any copper component (wiring and tubing).

9. Circuit Protective and Control Devices

9-1. Electricity, when properly controlled, is of vital importance to the operation of refrigeration equipment. When it is not properly controlled, however, it can become dangerous and destructive. It can destroy components or the complete unit; it can injure personnel and even cause their death.

9-2. It is of the greatest importance, then, that we take all precautions necessary to protect

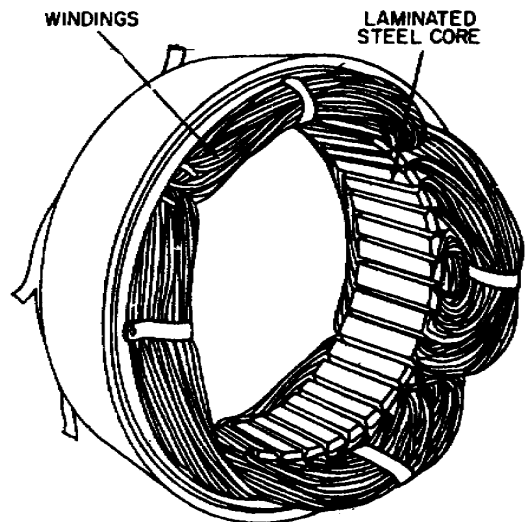

Figure 46. Compensated series-wound universal motor.

the electrical circuits and units and that we keep this force under proper control at all times. In this section we shall discuss some of the devices that have been developed to protect and control electrical circuits.

9-3. **Protective Devices.** When a piece of equipment is built, the greatest care is taken to insure that each separate electrical circuit is fully insulated from all others so the current in a circuit will follow its intended individual path. Once the equipment is put into service, however, there are many things that can happen to alter the original circuitry. Some of these changes can cause serious troubles if they are not detected and corrected in time.

9-4. Perhaps the most serious trouble we can find in a circuit is a direct short. You have learned that the term is used to describe a situation in which some point in the circuit, where full system voltage is present, comes in direct contact with the ground or negative side of the circuit. This establishes for current flow a path that contains no resistance other than that in the wire carrying the current, and these wires have very little resistance.

9-5. You will recall that, according to Ohm's law, if the resistance in a circuit is extremely small, the current will be extremely great. When a direct short occurs, then there will be an extremely heavy current flowing through the wires.

9-6. To protect electrical systems from damage and failure caused by excessive current, several kinds of protective devices are installed in the systems. Fuses, circuit breakers, and thermal protectors are used for this purpose.

9-7. Circuit protective devices, as the name implies, all have a common purpose: to protect the unit and the wires in the circuit. Some are designed primarily to protect the wiring. These open the circuit in such a way as to stop the current flow when the current become greater than the wires can safely carry. Other devices protect a unit in the circuit by stopping current flow to it when the unit becomes excessively warm.

9-8. **Control Devices.** The components in an electrical circuit are not all intended to operate continuously or automatically. Most of them are meant to operate at certain times, under certain conditions, to perform very definite functions. There must be some means of controlling their operation. Either a switch or a relay, or both, may be included in the circuit for this purpose.

9-9. *Switches.* Switches are used to control the current flow in most electrical circuits. A switch is used to start, to stop, or to change the direction of the current flow in the circuit. The switch in each circuit must be able to carry the normal current of the circuit and must be insulated heavily enough for the voltage of the circuit.

9-10. The toggle switch (as shown in fig. 47 along with the knife switch which is used to simplify the operation of a toggle switch) is used more than any other kind of switch, but there are others, such as pushbutton, microswitch, rotary selector, and even relays and magnetic motor starts, which can be classified as switches since they operate, start, and stop current flow in a circuit.

9-11. *Magnetic motor starters.* A magnetic motor starter is wired to satisfy a particular application; and there are numerous applications, so we will not attempt to cover all of them. Figure 48 shows a pump, air conditioner, and fan operating through motor starters. Look at figure 48 and notice the two single-pole single throw (SPST) switches, thermostat, holding coils, motor protectors, and step-down transformer. Also notice that three-phase equipment must have protective devices in at least two wires, but single-phase equipment may be protected by one protective device.

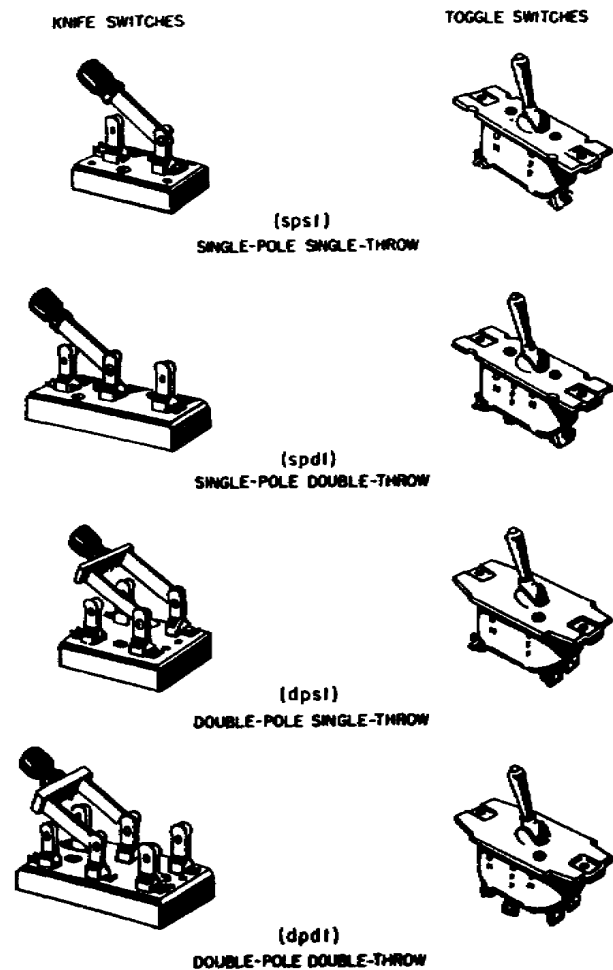

Figure 47. Various knife and toggle switches.

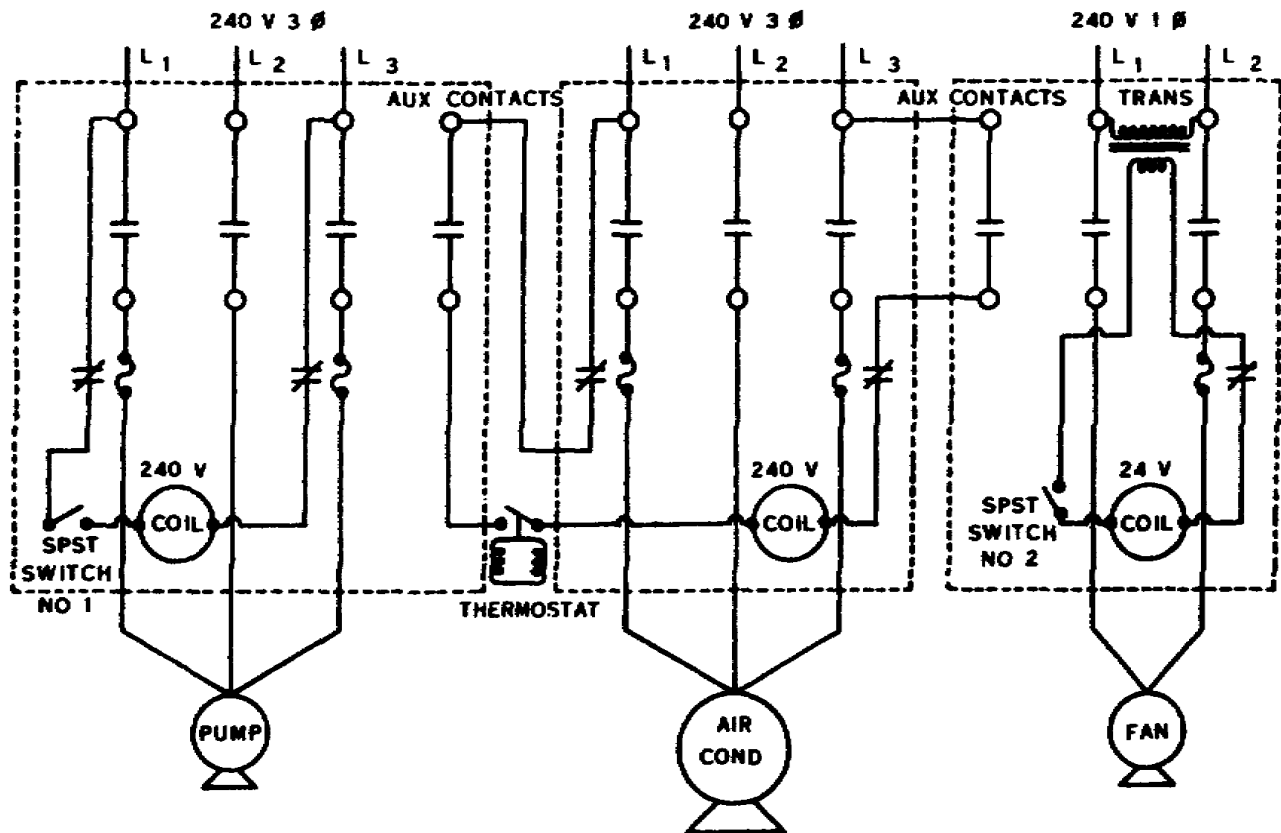

Figure 48. Use of magnetic motor starters.

9-12. In figure 48, the air conditioner will not operate unless the fan and pump holding coils are energized, and the thermostat switch is closed. Notice that the control circuit for the air conditioner is wired in series through the auxiliary contacts of the fan and pump motor starters. Also, notice that a low voltage may be used to control a higher voltage with the use of a step-down transformer.

9-13. If switches Nos. 1 and 2 are closed, the pump and fan will operate but the air conditioner will not until the thermostat completes the circuit for its holding coil. If an overload develops in the pump or fan, the heaters open the respective control circuit, which in turn breaks the control circuit for the air conditioner.

9-14. **Maintenance and Troubleshooting.** Most of the troubles in motor starters will be in the load contacts, holding coil, or heaters. A voltmeter can be used to check

the load contacts, if the voltmeter leads are connected in parallel to each set of contacts and the holding coil is energized. The voltmeter should read zero. If it does not, then the contacts need to be cleaned or replaced. With power *off*, the heaters and the holding coil may be checked with the ohmmeter. Heaters should be sized correctly to give protection to the motor; if undersized they would cause nuisance tripping in normal current flow.

9-15. In this chapter you have studied the fundamentals of electricity, circuits, Ohm's law, transformers, magnetism, electrical meters, circuit protective and control devices, and motors that are used to drive refrigeration equipment. Let's continue with another type of drive for refrigeration equipment, the gasoline engine.

REVIEW EXERCISES

These review exercises are intended to assist you in studying the material in this memorandum. The figures following each question correspond to the paragraph numbers that contain information pertaining to the exercise. In order to obtain the most benefit from the review exercises you should try to work them before you look at the answers in the back of the memorandum. Do not send in your solutions to the review exercises.

CHAPTER 1

Objective: To show knowledge of the fundamentals of electricity, circuits, motors, circuit protectors, troubleshooting, and safety.

1. What type of electricity does a generator produce? (1-4)

2. Define voltage, current, and resistance. (1-6, 10)

3. Why are alloys of nickel and chromium used in heater elements? (1-11)

4. The resistance of copper wire is determined by three things. What are they? (1-12)

5. What type metal is used to make a permanent magnet? (1-16)

6. What determines the output frequency of an ac generator? (2-10)

7. Given an electrical potential of 110 volts and a resistance of 55 ohms, find the amperage draw. (3-4)

8. Given a resistance of 12 ohms and a 20-amp current draw, find the electrical potential. (3-5)

9. Given a 5-amp current draw and an electrical potential of 110 volts, find the resistance in ohms. (3-6)

10. If a dc motor draws 1 ampere of current when connected to 746 volts, what is the horsepower of the motor? (3-25, 27)

11. What is the electrical symbol for inductance? (4-8)

12. What effect does a capacitor have on an ac motor circuit? (4-10; Fig. 17)

13. When will the apparent power be equal to the true power in an ac circuit? (4-12)

14. Will a transformer operate on any dc circuit? (5-1)

15. Name the three primary parts of a transformer. (5-2)

16. List the four types of transformer connections. (5-21)

17. What is the purpose of the various size resistors connected in series with the voltmeter movable coil? (6-3)

18. Why is a shunt connected in parallel with the ammeter meter circuit? (6-4)

19. When will maximum current flow through the ohmmeter circuit? (6-7)

20. Before using a dc meter on an ac circuit, what must be added to the circuit? (6-9)

21. What the purpose of the wattmeter? (6-10)

22. How would a voltmeter be connected to check or a blown fuse? (6-20)

23. What must be done to the circuit before making a continuity check in a parallel circuit? (6-30)

24. What determines the speed of rotation of an ac motor? (7-2)

25. How many windings must a single-phase induction motor have? (7-5)

26. What would happen to the split-phase motor if the start winding failed to disengage? (7-15)

27. Which of the single-phase motors has the best running characteristics and highest starting torque? (7-18)

28. How is a three-phase motor started? (7-23)
29. Why does a reluctance motor operate at exactly synchronous speed? (7-26)
30. What type motor may be used on either ac or dc? (7-28)
31. How often should a motor be lubricated? (8-3)
32. What are circuit protective devices used for? (9-7)
33. On three-phase equipment how many protective devices must be in the circuit? (9-11)
34. In figure 66 the air conditioner will not operate if the fan is not on. Why? (9-12)
35. Where will most of the troubles be located in a magnetic motor starter? (9-14)

Fundamentals of Gasoline Engines

Occasionally you may be called upon to service engine-powered refrigeration units. You will find these engine-powered units on refrigerated vans, mobile field units, and some trailers used for electronic system maintenance.

2. Since you will be operating and servicing these units, you must possess a working knowledge of gasoline engine. Let's begin with a discussion of the four stroke cycle engine.

10. Principles of Operation

10-1. For a four stroke cycle internal-combustion engine to operate and deliver power, the following series of events must occur in the order illustrated in figure 49. A mixture of fuel and air must enter the cylinder and be compressed. The mixture must be ignited by some means, causing it to burn and expand. The expanding gases then force the piston down. The piston then must move upward, expelling the burned gases from the cylinder. This series of five events must take place time and time again in exactly the same sequence if the engine is to deliver power. To improve the efficiency of the engine, various valves are timed to open or close at a piston position slightly before or slightly after a dead-center position.

10-2. The two stroke cycle engine is a one that completes its cycle of operation in only two strokes, instead of four as in the four stroke cycle. Mechanically the two stroke cycle engine is slightly different. Some have the intake and exhaust ports placed in the cylinder wall, while others may use a combination of intake ports and mechanically operated exhaust valves in the combustion chamber. When ports are used and the piston moves down on its power stroke, it first uncovers the exhaust port to allow burned gases to escape and then uncovers the intake port to allow a new air-fuel mixture to enter the combustion chamber. On the upward stroke, the piston covers both ports and at the same time compresses the new mixture in preparation for ignition and another per stroke.

10-3. Theoretically the two stroke cycle engine should produce twice as much power as a four stroke cycle engine of the same size. This is not true, because fuel is wasted and power is lost when some of the incoming fuel mixture mixes with the exhaust gases and is exhausted out of the engine. In this manner the volumetric efficiency of the engine is reduced considerably. Volumetric efficiency is the ability of an engine to take in enough air to insure complete combustion. However, a two stroke cycle produces more power output per unit weight than a four stroke cycle engine.

10-4. So far all we've discussed is the operation of gasoline engines. Now we will over the servicing of gasoline engines. We will start with the lubrication system.

11. Maintenance of Lubrication System

11-1. The lubricating system of an engine includes a number of different units. In this system the oil is picked up from the oil pan reservoir by the pump. The pump is usually driven by the camshaft. An oil strainer is placed in series with the pump to remove foreign substances, such as metal particles, dirt, etc, from the oil. The oil is forced through metal tube and galleries in the engine block to various parts of the engine. It is then either splashed or forced on the moving parts of the engine after which the oil returns to the oil pan reservoir, thus completing the cycle.

11-2. In order for the lubrication system to function properly, the operator must observe and record the oil pressure at predetermined intervals, maintain the proper oil level in the crankcase of the engine, and change the oil and oil filter element, as specified by the technical manual applicable to the specific engine.

11-3. **Oil Pressure Gage.** The oil pressure gage indicates the resistance of the oil being circulated through the engine. The resistance is generally

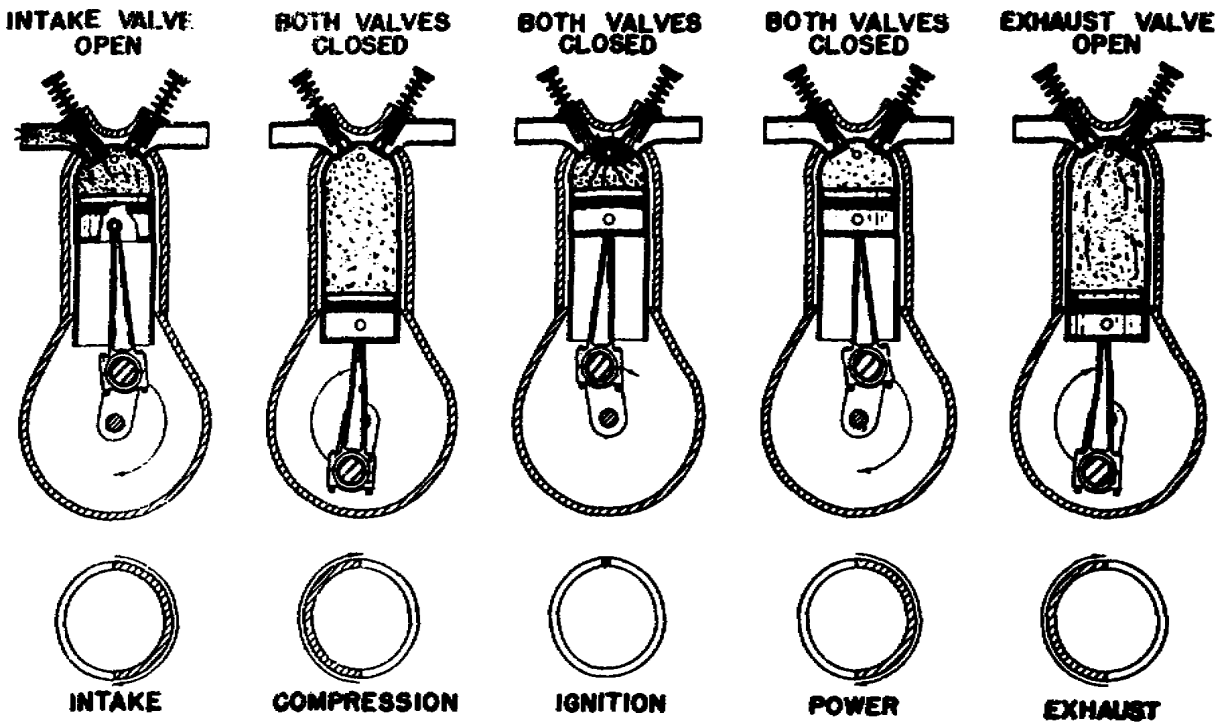

Figure 49. Four stroke five event cycle principle.

measured in pounds per square inch. A pressure gage does not show how much oil there is in the crankcase. It merely shows that oil is being pumped sufficiently to create an indicated pressure. If the oil pressure gage does not show any oil pressure, the engine must be stopped, since it is an indication that the oil is not circulating and lubricating the moving parts. The engine will be severely damaged if it is allowed to operate without oil pressure for a short length of time.

11-4. **Oil Level Gage.** The oil level gage rod is usually of the bayonet type, similar to that used on automobiles, and is used to check the oil level in the crankcase. The gage rod is usually stamped at "add oil" and "full" levels. Oil level on the bayonet gage rod should be taken only when the engine is not operating and the engine oil is at normal operating temperature. Always keep the oil above the "add" mark.

11-5. **Oil Filter.** The primary function of the oil filter is to filter out contaminating substances as the oil passes through the filtering element. Two types of oil filters are used: one is the sealed element type and the other is the replaceable element type.

11-6. Most oil filters are designed with a bypass valve which permits free circulation of the lubricating oil if the filter element becomes clogged. Normally a filter element should be changed when the lubricating oil in the engine is changed. This change should be performed at such intervals as recommended by the applicable publications.

11-7. Use care when replacing the filter - to avoid damaging the oil lines or the oil line fittings. Our next discussion will be the maintenance of the fuel system.

12. Maintenance of Fuel System

12-1. A gasoline engine fuel system consist essentially of a storage tank for the fuel, a fuel filter to clean the fuel, a fuel pump to transfer the fuel from the tank to the carburetor, and a carburetor to mix the fuel with the air.

12-2. **Fuel Filter.** Fuel filters may be of various designs and located at any point between the fuel tank and the carburetor. In figure 50 the fuel enters the bowl and pass up through the filter screen before it flows out through the outlet. Water, or any solid caught by the screen, settles to the bottom of the bowl. The bowl can be removed and cleaned.

12-3. **Fuel Pump.** The fuel pump pumps gasoline from the fuel tank, through the fuel filter, to the carburetor float chamber, at approximately 3 psi.

12-4. **Carburetor.** The basic function of the carburetor is to meter the air and fuel in varying percentages according to the engine requirements. The most desired mixture has an air-fuel ratio of 15 to 1-15 parts of air to 1 part of fuel by weight. A 15 to 1 ratio is referred to as a normal or medium mixture. A mixture con-

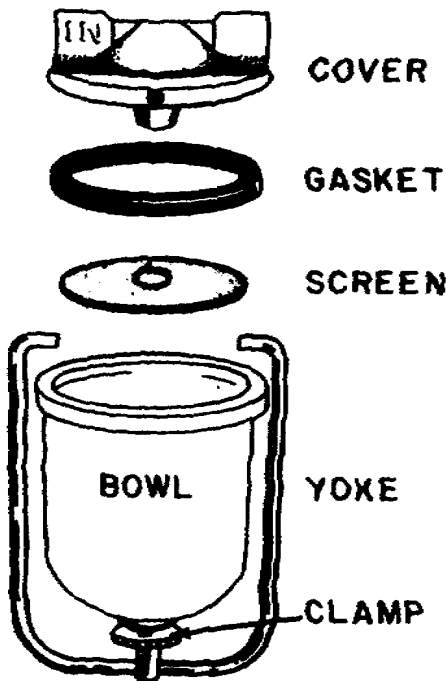

Figure 50. Fuel filter.

taining less air is known as a rich mixture. Maximum horsepower is obtained at a ratio of 12 or 13 to 1; maximum economy, however, is obtained with a 15 to 1 ratio. The carburetor must automatically vary the proportion of air and fuel to meet the changing conditions under which the engine operates.

12-5. To procure maximum horsepower and maximum economy from an engine, it is sometimes necessary to make certain carburetor adjustment. The

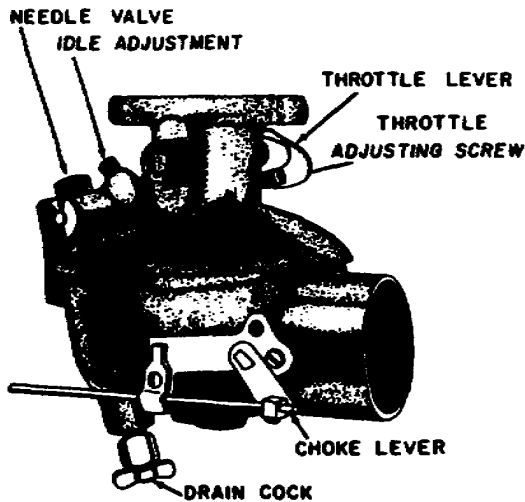

Figure 51. Carburetor.

carburetor shown in figure 51 is one used with a small air-cooled engine which operates a 25-cubic foot refrigerator. This carburetor has three adjustments: the main needle valve, the idle adjusting screw, and the throttle adjusting screw. The main needle valve meters gasoline to the engine at operating speeds, the idle adjusting screw meters gasoline to the engine at idle speed, while the throttle adjusting screw adjusts the idling speed of the engine. Most carburetors have only the latter two adjustments. In these carburetors the gasoline is metered to the engine automatically.

12-6. **Air Cleaner.** The carburetor air cleaner must be kept clean to prolong engine life. Two types of air cleaners are used. They are the wet and dry types. At certain intervals, as recommended by the applicable publication, the wet filter is disassembled, washed in nonflammable cleaning solvent, reassembled, and refilled or sprayed with oil. Dry type cleaners are replaced at

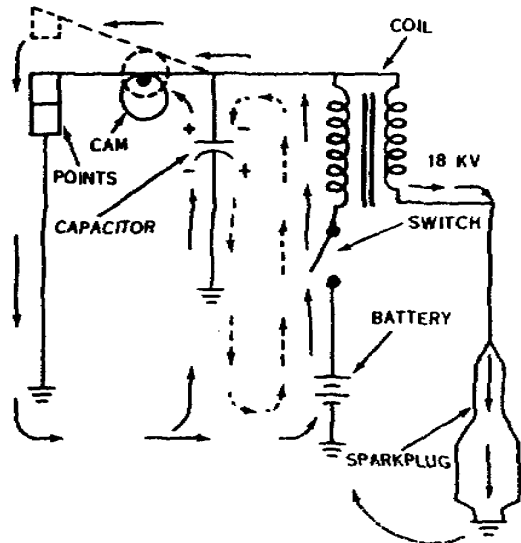

Figure 52. Ignition system.

prescribed interval. They must never be oiled; however, in emergencies they may be cleaned with compressed air.

12-7. We've mentioned previously that the fuel-air mixture must be ignited by an electric spark from a spark plug; let's discuss the system that causes this function.

13. Maintenance of Ignition System

13-1. The complete function of the ignition system is shown in figure 52, but let's discuss each one separately.

13-2. **Spark Plugs.** Spark plugs should be removed, cleaned, and inspected at intervals prescribed by the manual for the particular engine. This operation is important because dirty spark

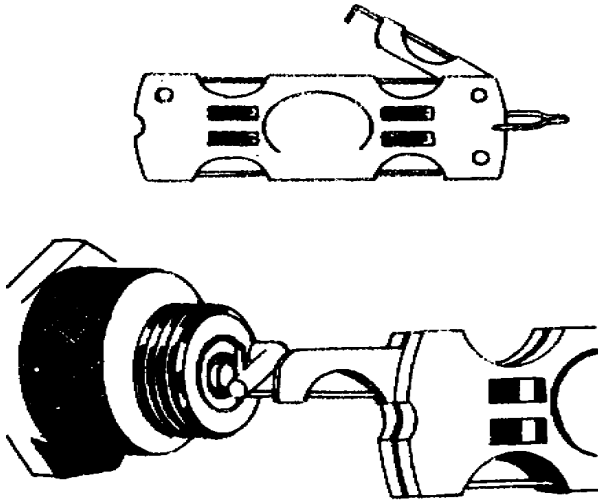

Figure 53. Adjusting spark plug gap.

plugs and plugs that have insufficient or too large a gap between the electrodes will cause hard starting and irregular firing of the engine.

13-3. Using a thickness gage, as shown in figure 53, adjust the gap between the electrodes to the specified amount recommended by the manual for the particular engine. The electrodes are spaced properly when the correct thickness gage can be lightly drawn between them.

13-4. The coil (transformer) is used to step up the voltage to approximately 18,000 volts dc. To do this the primary of the coil is connected to a set of points. These points open and close to create pulsating dc that can be stepped up. The secondary side of the coil which also produces pulsating dc is connected to the rotor in the distributor and from there to each spark in turn.

13-5. The condenser (capacitor) is in the circuit to help collapse the magnetic field and reduce arcing at the points.

13-6. **Distributor.** The distributor with its components is shown in figure 54. The distributor points should be inspected periodically. To inspect the condition of the point, stop the engine and remove the distributor cap and rotor. Then examine the distributor breaker points for pits or evidence of overheating. If the points are badly pitted or burned, they should be replaced.

13-7. After the points are replaced, adjust the clearance when fully open as prescribed by the publication for the specific engine. Also, replace the rotor and cap.

13-8. **Storage Battery.** The storage battery is a very vital part of the electrical and ignition system and must be properly maintained for dependable automatic operation.

13-9. The most common type of storage battery is the lead and acid type. It is so called because the plates

are composed of lead and the electrolyte is a solution of acid.

13-10. A battery must be tested periodically to determine its state of charge. To test the specific gravity of the electrolyte of each cell, remove the filler caps, being careful to prevent dirt or foreign matter from falling into the cells.

13-11. Use a hydrometer to test the specific gravity of each cell. If the specific gravity is less than 1.175, increase the generator charging rate, or recharge the battery.

13-12. If the unit is being operated in a tropical or hot climate and the specific gravity is over 1.225, the charging rate should be reduced. If the unit is operating in a temperate climate, the charging rate should not be reduced unless the specific gravity is over 1.290. When operating the unit in a frigid or cold climate, always keep the battery fully charged.

13-13. The battery electrolyte level should be inspected daily. When available, distilled water should be used to refill a storage battery. If the water level is low, refill each cell so that the level is about one-half of an inch above the top of the plates. It is important that the electrolyte level be properly maintained at all times. It is also very important that the specific gravity be

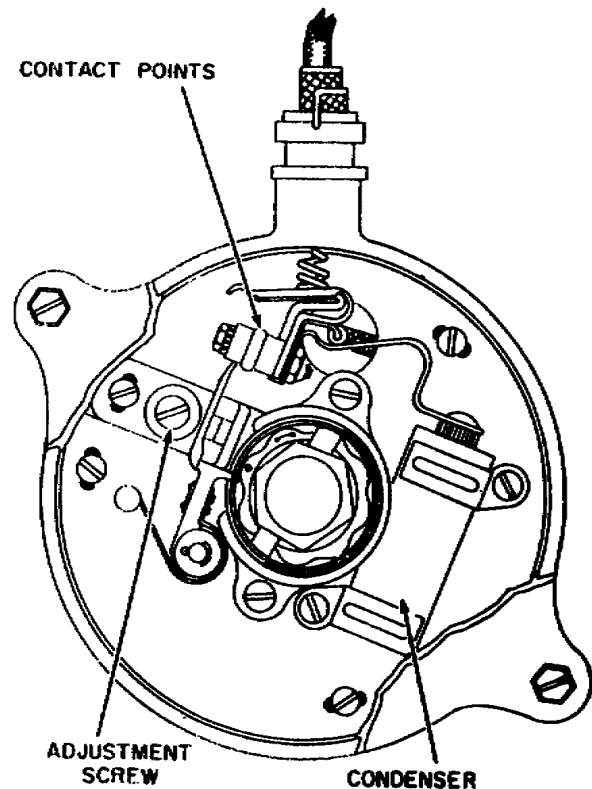

Figure 54. Distributor.

maintained at sufficient strength to prevent freezing in extremely cold locations.

13-14. If the electrolyte level is too low to obtain a reading with the hydrometer, refill the battery with distilled water and allow the unit to operate for an hour or more before taking a hydrometer reading; otherwise an accurate, specific gravity test cannot be obtained.

13-15. Wash the battery terminals, cable clamps, and cables with a solution of water and soda. See that the vents in the filler caps are open. To keep the terminals and battery cable clamps from corroding, coat them with grease. Do not drop a battery, and don't pound on the terminal. At intervals, remove the battery from its cradle, clean the cradle, and coat it with rust preventive compound.

13-16. Now that we have oil in the engine, fuel in the tank, and voltage to the spark plug, we can start the engine. Wait, we've forgotten another important system - the cooling system. We must have a system that will keep the engine at a normal temperature. We had better discuss this topic a little further.

14. Maintenance of Cooling System

14-1. All internal combustion engines are equipped with some type of cooling system to dissipate the great amount of heat they generate during operation. About one-third of the heat generated by combustion must be dissipated by the cooling system. Cooling systems are classified into two categories - liquid cooling and air cooling.

14-2. **Liquid Cooling.** A simple liquid-cooling system consists of a radiator, a circulating pump, a fan, a thermostat, and a system of water jackets and water passages within the engine.

14-3. If the engine temperature runs abnormally high, clean the exterior of the radiator by blowing compressed air through the fins to dislodge any foreign material and dead insects. If the temperature still runs high, heating may be due to an accumulation of sludge in the radiator. It is then best to drain and flush the radiator and engine block with deaerated water. Refill the radiator with soft water if it is available. If treated water is not available, then use clear tap water, but drain and flush the system more often.

14-4. For operation below freezing or if the engine should be standing idle at temperatures below freezing without being drained, ethylene glycol or a similar antifreeze should be added in sufficient quantity to prevent freezing at the lowest anticipated temperature.

14-5. **Air Cooling.** Air-cooled engines are designed in such a manner that the engine cylinder and head are

cooled by forced circulation of air provided by vanes on the flywheel. The blower case inclosing the flywheel and the baffles around the cylinder control the flow of air. Keep the system clean to prevent overheating of the engine and to assure uniform air velocity for proper cooling. When the flywheel vanes, cylinder, and cylinder fins become coated with dust and dirt, the engine blower case must be removed to clean the units. Using a stiff bristle brush or a scraper, remove all traces of dirt from the flywheel vanes and the cylinder and cylinder head fin. When maintaining cylinder fins it is important that fins not become bent or otherwise damaged, as this will result in hot spots within the cylinder.

14-6. Well, we've got the engine running normally; now we'll connect it to the compressor and get some work done.

15. Maintenance of Drive Mechanism

15-1. All drive belts should be examined regularly for wear, breaks, and adjustments. A worn belt becomes bright and smooth and tends to ride the bottom of the pulley or to slip when under a load. Continuous rubbing of the side of a belt wears down the edges and decreases the efficiency of its drive. Excessive friction from the contact with abrasive dust causes internal breakdown of a rubber belt. The presence of stray lubrication near a rubber belt should be checked. Oil and grease soften and deteriorate rubber. However, some flexible V-belts are made of a special composition which is not affected by grease or oil.

15-2. A belt which runs loose may snap in two. Low belt tension causes reduced and unsteady output. Unusual tautness brings on rapid wear of the belt, motor bearing, and compressor bearings.

15-3. If a belt shows indications of wear and cracks, it should be replaced. Always replace belts in matched sets if at all possible. To check the tension of the drive belt, which operates small compressor units, deflect the belt at a point halfway between the engine pulley and the compressor pulley. The deflection at this point, with a 10-pound pressure, should be between 1/2 inch and 3/4 inch. Adjust the belt as required or replace with a new one of the correct size. During the inspection and maintenance of V-type belts it must be remembered that the driving force is on the sides of the pulley and not on the bottom of the pulley groove.

15-4. The four-stroke cycle engine is most common to the career field. The operation of the engine depends upon proper maintenance. Each subsystem - fuel, electrical, and cooling - must work in harmony for peak performance. We've

discussed the maintenance to be performed on each system. The most important service that can be given an engine is proper lubrication. A large percentage of powerplant breakdowns are a direct cause of insufficient lubrication. Lubricate each powerplant according to the recommendations prescribed by the applicable

publications. The frequency of maintenance is outlined in publications furnished by the manufacturers of the engines or by the TO when available.

15-5. Since we have covered the prime movers for refrigeration equipment, let's study the physics of refrigeration so the prime movers can be put to use.

CHAPTER 2

Practice Exercises

Objective: To show knowledge of the fundamentals and maintenance of the gasoline engine.

1. List the series of five events a four stroke cycle engine must go through to delivery power. (10-1)
2. When should the engine oil be checked? (11-4)
3. To obtain maximum economy what should the air-fuel ratio be? (12-4)
4. What type of electrical power is delivered to the ignition coil? (13-4)
5. What is the purpose of the condenser in the engine ignition circuit? (13-5)
6. What is the most common storage battery composed of? (13-9)
7. When should ethylene glycol be used? (14-4)
8. What is the best way to check a drive belt for correct tension? (15-3)

CHAPTER 3

Physics of Refrigeration

When venturing into the field of refrigeration, the first thing to learn is what goes on within the unit to produce the "cold." When we talk about something being "cold" we simply mean that it has less heat in relation to something else. Every substance will have some heat until the substance reaches absolute zero.

2. Heat is not destroyed in producing the cold but is simply removed from the place where it is unwanted. Heat is also in a mechanical refrigeration system to help remove the unwanted heat.

3. The particular phase of natural science with which we are concerned involve the study of conditions under which certain changes take place; for example, when a solid melts or when a liquid boils.

16. Thermodynamics

16-1. Before we go into the study of thermodynamics let's see what it means. "Thermodynamics is the physics that deals with the mechanical action or relations of heat processes and phenomena." One of the laws of thermodynamics is a formula which states that 778 foot pounds of work is equivalent to the heat energy of one Btu. Another law is a statement that heat will only transfer from a higher temperature to a lower temperature.

16-2. **Heat.** All substances have heat; however, some will have more heat than others. Heat is the movement of the molecules within the substances. The more they move the hotter the substance becomes. To completely stop this movement the substance must be reduced in temperature to absolute zero.

16-3. **Cold.** We use this term to show that an object has less heat than something else. Cold is not produced but is merely a result of removing heat, which removal slows down the molecular movement. Many substances change their state from a solid to a liquid, a gas or vice versa, with the addition or subtraction of heat. Other substances change their state by sublimation; in other

words, they change from a solid directly into a gas. There are different types of heat and different methods of transferring this heat; but first let's look at some types of heat.

16-4. **Sensible Heat.** Sensible heat is the amount of heat that can be added to or subtracted from a substance without changing its state. Sensible heat can be measured by a thermometer and detected by the body senses when present in appreciable amounts.

16-5. **Latent Heat.** Latent heat is hidden heat present in a substance. When ice at 32° F. melts into water at 32° F., a change of state takes place. During this change, a certain amount of heat is required to melt the ice to water at 32° F. This heat which causes the change of state is known as the latent heat of fusion. Now if the water at normal atmospheric pressure is heated until it reaches 212°, it will not rise above the temperature until it is all changed into steam (vapor). The heat that changes a substance from a liquid to a vapor is known as the latent heat of vaporization.

16-6. The graph shown in figure 55 indicates that the amount of heat required to change 1 pound of water from a solid to a liquid is 144 Btus. To change 1 pound of water from a liquid to a gaseous state requires a total of 970 Btus.

16-7. **Specific Heat.** The fact that it takes 1 Btu to raise the temperature of 1 pound of water 1° does not mean that this is true for all substances. Some substances require more heat while others call for less heat to raise their temperature equal amounts. Water is used for comparison, and the amount of heat required as compared to water is the specific heat of a substance. A few specific heat values are given for different substances in figure 56.

16-8. **Heat Transfer.** Heat can be transferred from a hot object to a cooler object until both are equal in temperature. Heat can be transferred by any one of three different methods - conduction, convection, and radiation - or by a combination of these same methods.

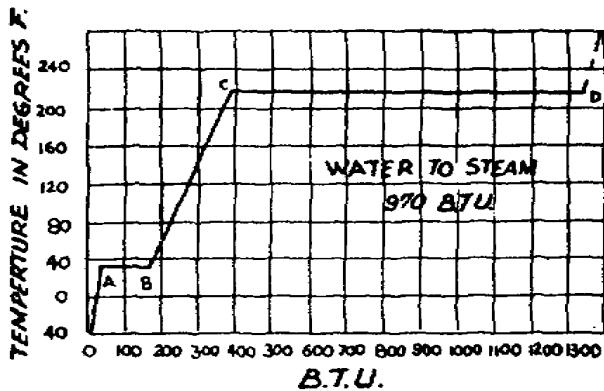

Figure 55. The three states of water and the heat required to make change state atmospheric pressure.

16-9. *Conduction.* When heat is transmitted from one part of a substance to another part of the same substance or from one substance to another in direct contact the process is termed "conduction." To verify these two statements by experiment, use a metal rod, as illustrated in figure 57, placing one end over a flame. As the heat is absorbed, the molecules become active, and in a short time the cooler portion of the metal rod becomes warm. Metals are good conductors of heat; but other materials, such as glass or cork, aren't. Materials which offer resistance to the flow of heat are known as insulators or poor conductors.

16-10. *Convection.* Convection will be clear to you if you will follow the flow of air as it is transmitted through a heating system. When air is heated, it expands and becomes lighter because of the change in density. Cooler heavier air flows in under the warm air and forces it upward. Then, as the warm air becomes cooler it

MATERIAL	Specific Heat (B.T.U.#)
Wood	327
Water	1
Ice	504
Iron	129
Mercury	0333
Alcohol	615
Copper	095
Sulphur	177
Glass	187
Graphite	200
Brick	200
Glycerine	576
Liquid Ammonia at 40°F	11
Carbon dioxide at 40°F	6
Methyl Chloride at 40°F	38
Sulphur dioxide at 40°F	35

Figure 56. Specific heat values.

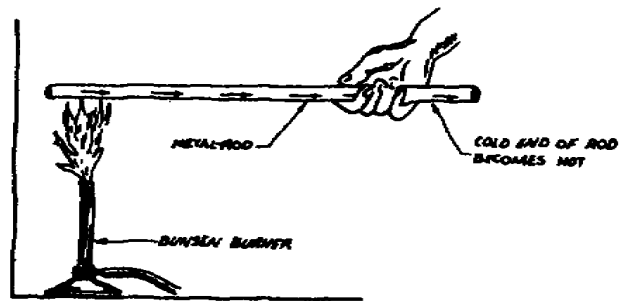

Figure 57. Heat transfer by conduction.

contracts, becomes more dense (heavier), and falls back to its source, where it is heated again. Thus, a circulation of air is set up which continues as long as heat is provided. Figure 58 shows how heat is transferred by convection.

16-11. *Radiation.* Heat may be transmitted from one place to another without the use of any material carrier. The best example of this method of transfer of heat is found in the radiation of energy from the sun to the earth. We know that the atmosphere of the earth is negligible at a comparatively short height above the earth and that the rest of the more than 90 million miles up to the place where the sun's atmosphere begins is filled with little or nothing. Therefore we know that both light and heat energy from the sun must come through space. Such a method of transfer is called radiation.

16-12. Radiation is the process of emitting radiant energy in the form of rays or particles, as shown in figure 59. In this case, a person's hand feels warm, even though it is a considerable distance from the source of heat. The rays or particles pass through the air and heat the hand more than the air between.

16-13. The transmission of heat by these three mediums can be controlled according to the required needs. Conduction is aided-by providing

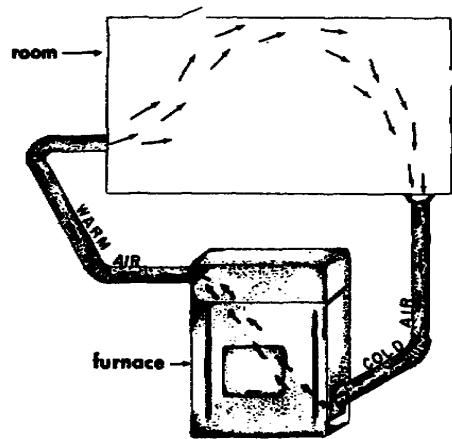

Figure 58. Heat transfer by convection.

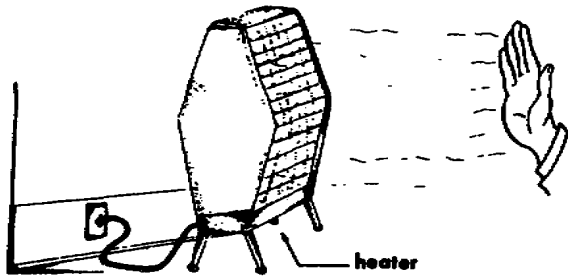

Figure 59. Heat transfer by radiation.

large conducting surfaces and good heat-conducting materials, such as iron, silver, or copper. Convection may be assisted by speeding up the flow of air, as in a forced-air circulation system. The flow of heat can also be controlled by dampers and thermostats according to one's desire. Dark colors usually absorb heat while light colors reflect heat. For this reason, a certain surface finish may radiate heat more efficiently than another. This is an aid to heating by radiation.

16-14. **Temperature.** The relative hotness of a body is termed "temperature." This is not the quantity of heat in the body substance, but merely its degree of warmth. An ordinary thermometer is used for the measurement of temperature.

16-15. Two types of scales that are in general use for temperature measurement are the centigrade and the Fahrenheit. Figure 60 compare the two sales. Looking at the centigrade scale, you can see that 0° is the freezing point and 100° the boiling point of water. There are 100 divisions on the centigrade scale compared to 180 division on the Fahrenheit scale. Water freezes at the 32° point and boils at the 212° point on the Fahrenheit scale.

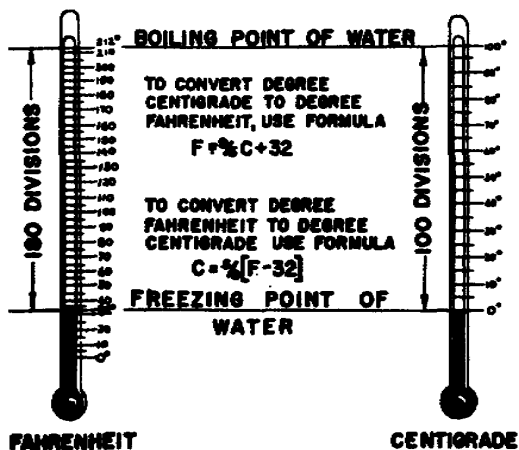

Figure 60. Comparison of Fahrenheit and Centigrade scales.

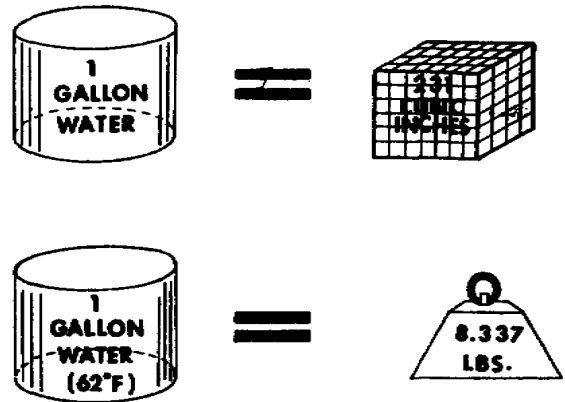

Figure 61. Density, volume, and weight.

16-16. It becomes necessary at times to convert from Fahrenheit to centigrade or from centigrade to Fahrenheit temperatures. A simple formula for converting these temperatures has been used by all members of the refrigeration trade. When converting Fahrenheit temperatures to centigrade, subtract 32° from the Fahrenheit temperature and multiply the remainder by .556 (5/9). To change centigrade temperatures to Fahrenheit, multiply the centigrade temperature by 1.8 (9/5) and add 32°. This formula should be memorized for use not only in the study of refrigeration but also in the study of air conditioning.

16-17. **Density.** The density of a substance is the ratio of its mass or weight to its volume. The upper portion of figure 61 shows that volume may be given either in liquid measure as gallons or in cubic measure as cubic inches. One gallon

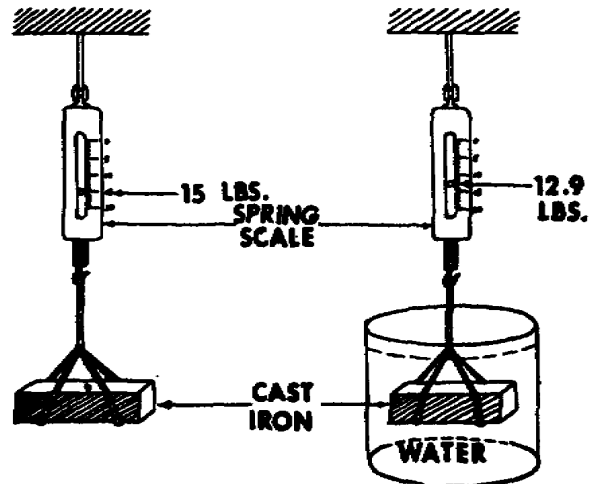

Figure 62. Determining specific gravity.

of water has a weight of 8.337 pounds at a temperature of 62° F.

16-18. The relative weight of liquids and solids is determined by specific gravity. Pure water is used as a standard reference with a value of 1. The specific gravity of cast iron may be figured by the method illustrated in figure 62. The weight of water which is displaced by a 15-pound bar of cast iron is 2.1 pounds. Divide 2.1 into 15 to get the specific gravity, which is about 7.1 for cast iron. The specific gravity of a liquid may be measured with a hydrometer such as is used with a storage battery. The float in a hydrometer is calibrated so that the scale gives a direct reading of the specific gravity of the liquid being tested.

16-19. The density of a gas is expressed by specific volume. The specific volume is the volume of 1 pound of the given gas under standard conditions (temperature of 68° F. and pressure of 29.92 inches of mercury). Next we shall consider what is meant by pressure and some of the effects of it.

16-20. **Pressure.** Before a refrigeration can operate normally, a pressure difference must exist between different units of the system. Consequently, pressure and its laws are important. Pressure is the force per unit of area expressed in pounds per square inch or pounds per square foot. The pressure of air on one's body at sea level is approximately 14.7 pounds per square inch, or 2117 pounds per square foot. Since there are 144 square inches in 1 square foot, 14.7 is multiplied by 144 to find the pressure per square foot:

$$14.7 \times 144 = 2116.8, \text{ or } 2117 \text{ \#/}\square$$

16-21. A material exerts pressure on its supporting surface. For example, a desk (solid) exerts pressure on the floor through its legs. If the legs were removed, the desk would fall. A liquid, such as water in a pail, exerts

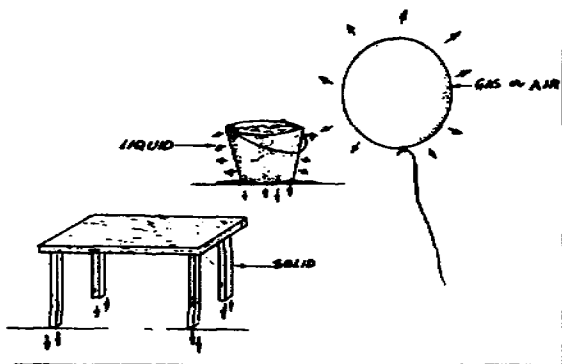

Figure 63. Types of pressure.

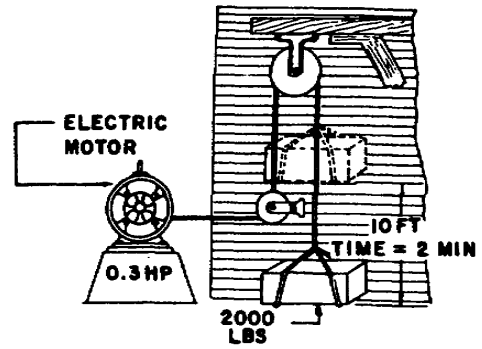

Figure 64. Illustration of horsepower.

pressure on the sides and bottom of its container. A good illustration of gas pressure is the pressure exerted by the substance used to inflate an ordinary balloon. The gas pressure inflates the balloon, supporting all points of its surface. Figure 63 illustrates the different types of pressures explained in this paragraph. When you learn about the refrigeration cycle, you will find that mechanical power is used to increase pressure.

16-22. **Work and Power.** An understanding of energy relations is essential to a complete knowledge of refrigeration. Energy is “the capacity to do work,” and whenever energy is spent there will be some work done. Work is “the force in pounds multiplied by the distance through which it acts.” The unit of work is called the foot-pound. One foot-pound is the amount of work done in raising 1 pound vertically a distance of 1 foot.

16-23. *Example.* What amount of work is done in lifting 2000 pounds a distance of 10 feet?

$$\text{Force X distance} = \text{work}$$

$$2000 \times 10 = 20,000 \text{ foot-pounds}$$

Power is the time rate of doing work. Mechanical power is termed “horsepower.” One horsepower

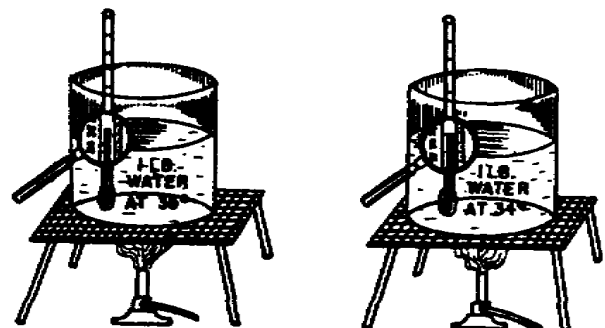

Figure 65. Unit of heat content.

does work at the rate of 33,000 foot-pounds per minute.

16-24. Referring to figure 64, you will see that if the 2000 pounds were lifted 10 feet in 2 minutes, the power required would be:

$$\frac{\text{Weight} \times \text{distance}}{\text{time} \times 33,000} = \text{horsepower}$$

$$\frac{2000 \times 10}{2 \times 33,000} = 0.3 \text{ horsepower}$$

16-25. **Energy.** In addition to mechanical power, we are concerned with electrical and heat energy. You will find in refrigeration that changes in heat energy are the basis of cooling. Electrical and mechanical energy are combined in most systems to produce changes in heat energy. The relationship between these three types of energy is expressed in terms of the following equivalents:

- 778 foot-pounds = 1 Btu
- 1 horsepower = 2,545.6 Btus/hr
- 1 horsepower = 746 watts

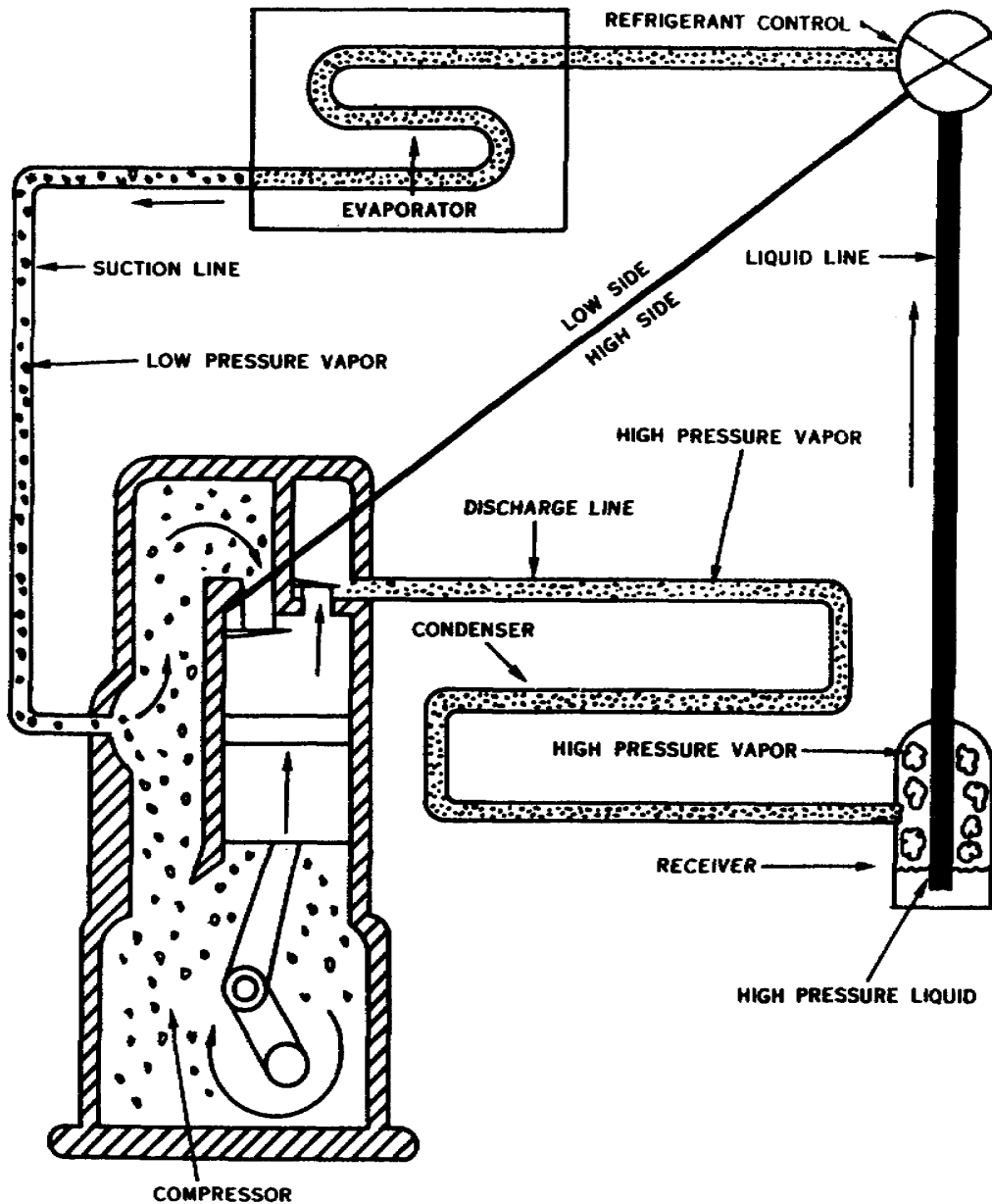

Figure 66. High and low side of system.

16-26. Scientists have a theory that heat comes from the vibration of the molecules in a substance. The rate of vibration determines the temperature, while the total energy involved in the movement of all the molecules of a substance determines the heat. Heat is measured in thermal units. The British thermal unit (Btu) is defined as the amount of heat required to raise the temperature of 1 pound of water 1° F.

16-27. Looking at the example (see fig. 65), you can see by the rise in temperature how 1 Btu was added to the water, causing a change in its heat content. Note that the state of the water does not change even though it has a higher temperature. Heat may be added without a change of state until the boiling point of the water is reached.

16-28. **Critical Temperature.** We can liquefy any gas by lowering its temperature or by increasing the pressure. However, there are temperatures at which gases cannot be liquefied regardless of the applied pressure. These are called the critical temperatures.

16-29. **Critical Pressure.** The critical pressure of a liquid is the pressure at or above which the liquid will remain a liquid regardless of the applied heat.

16-30. **Enthalpy.** Enthalpy is the total heat (energy) in 1 pound of a substance. The enthalpy for water is accepted at 32° F., where the accepted enthalpy

for refrigerants is at -40° F. Example: To find the enthalpy of 1 pound of 70° F. water, subtract 32° F. from 70° F. Total heat at 70° F. = 38 Btu.

16-31. **Entropy.** Entropy is a mathematical constant that is used by engineers for calculations of the energy in a system. Again, 32° F. and -40° F. are the accepted bases used in these calculations. Most of the refrigerant performance charts will show the constant entropy lines.

17. The Mechanical Refrigeration Cycle

17-1. Before studying the various changes which take place in the refrigeration cycle, it is necessary to see just how latent heat and pressure changes have become the foundation of modern refrigeration.

17-2. **Uses of Latent Heat.** When ice melts, its degree of temperature remains constant; however, it absorbs a large amount of heat in the process of changing from ice to water.

17-3. In the evaporator of the modern refrigerator, the refrigerant changes from a liquid to a gas. To make this change of state, heat must be absorbed by the refrigerant. This heat can only come from the space to be cooled. We can say that the cooling action within the cabinet takes place in the evaporator.

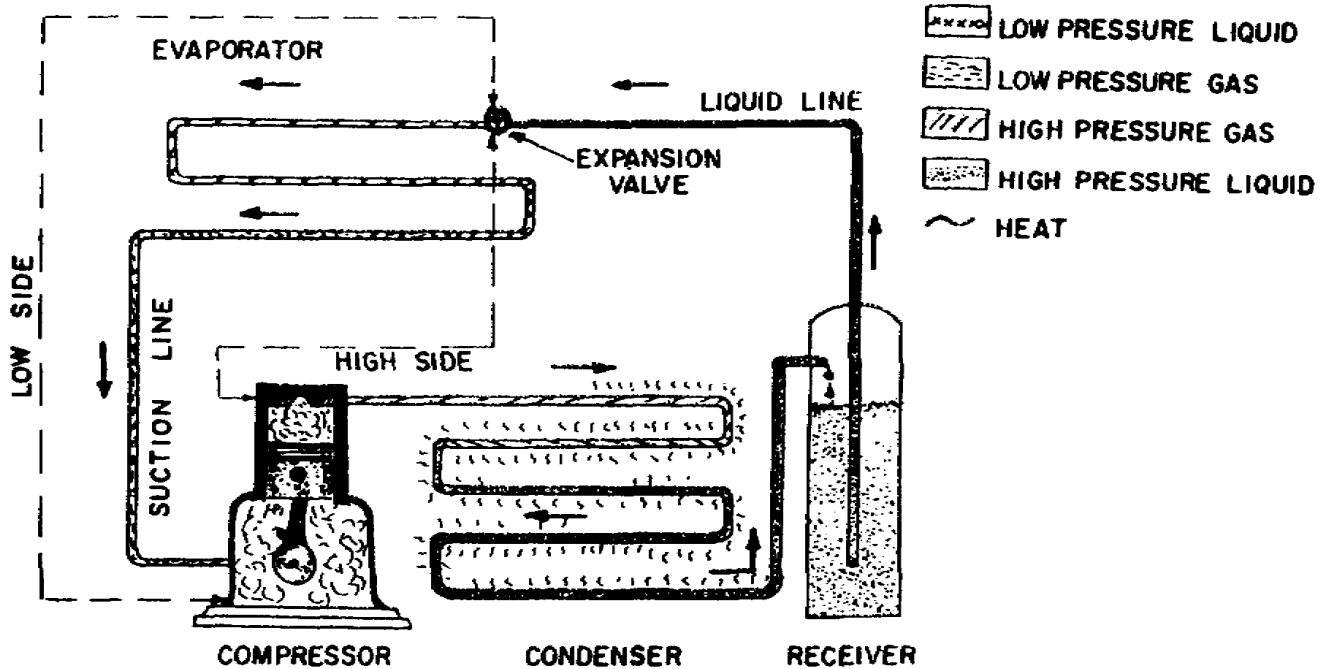

Figure 67. Compression system.

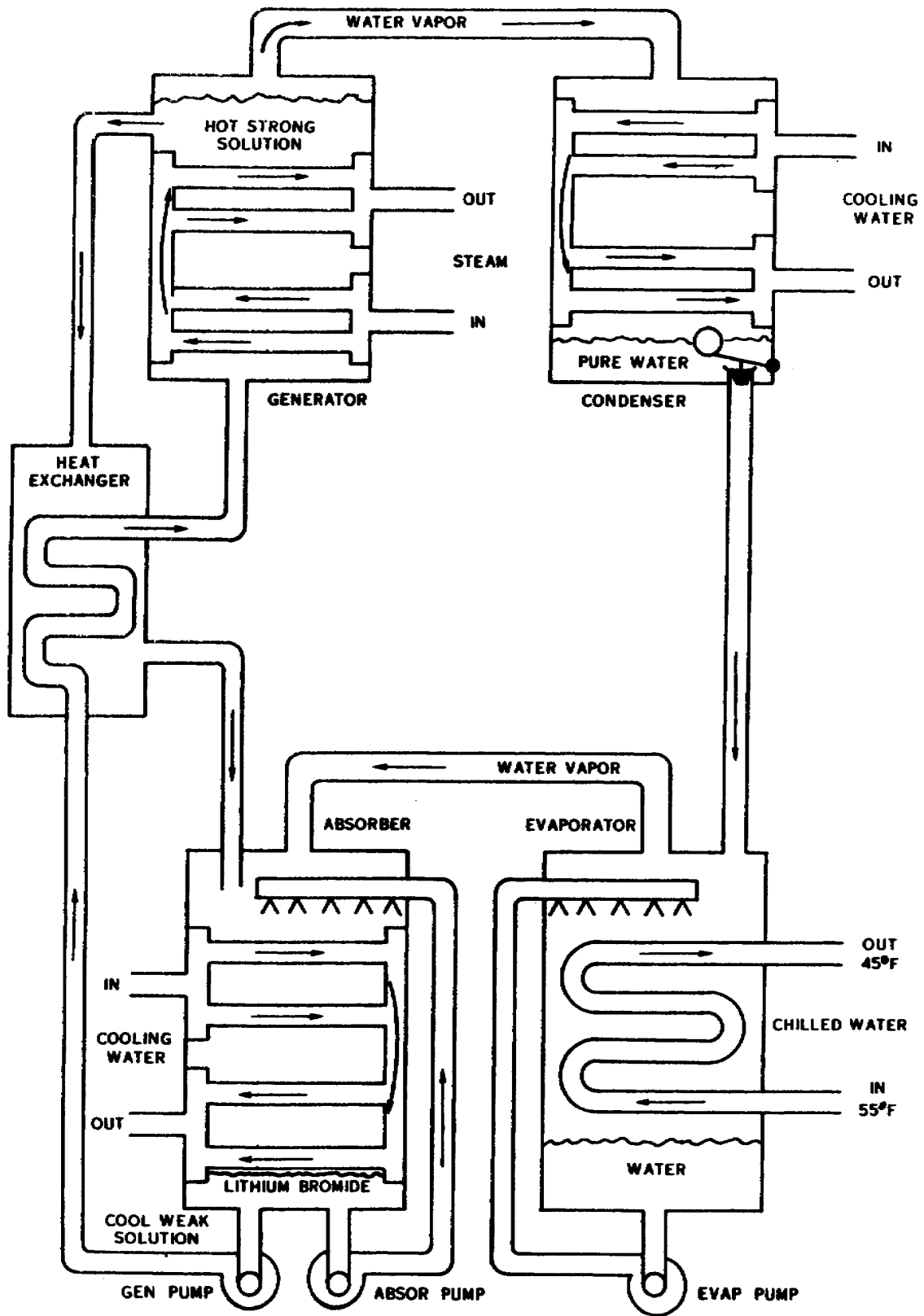

Figure 68. Absorption system.

17-4. The condenser is another area within the refrigeration cycle where latent heat of vaporization is used. The heat absorbed in the evaporator must be given up in the condenser. The condenser is surrounded by either air or water; and as the hot gas comes into contact with either of these mediums, it gives up its heat and condenses into a liquid.

17-5. You can see now that latent heat of vaporization plays an important role within the cycle, but let's not forget another important ingredient—pressure differences.

17-6. **Utilization of Pressure Difference.** In refrigeration, it is necessary to produce cold. This is made possible when differences of pressure are present. The high and low sides of a system and places where pressure varies during a cycle can be seen in figures 66 and 67. The reduction of pressure within the cycle takes place at the expansion valve. The refrigerant (of the R-12 type) boils at -21.7° F. under atmospheric pressure. If the pressure is reduced to 11.999 psia, the boiling point is lowered to -30° F. The cabinet temperature is maintained above this temperature; therefore, the heat of the cabinet will be readily absorbed by the refrigerant. Now you should have an understanding of how pressure differences are used in obtaining the refrigeration effect.

17-7. Now that we've covered latent heat and pressure differences, we are ready to apply these to the refrigeration cycle.

17-8. The refrigeration cycle is common to all machines made for lowering of temperature in our everyday living. The type of system used, however, depends upon the locality where the refrigeration is needed.

17-9. **Compression System.** Figure 67 illustrates the simplified refrigeration system. By applying the theory of latent heat and pressure differences, you can see what takes place in producing low temperatures. This illustration may be applied to any refrigerator regardless of size or shape.

17-10. Every system involves a cycle of one kind or another. We will trace through the entire cycle step by step.

17-11. As the piston moves down, low-pressure gas is emitted through the valve to fill up the cylinder. As the piston starts up, compression takes place because the gas is forced into a smaller space. As the gas is compressed, heat of compression is added. At the topmost position of the piston, the gas is forced through the exhaust valve into the condenser. The gas is at its highest pressure. The condenser is a series of tubes surrounded by a cooling

medium (air or a water). As the gas is forced through the tubes, the heat of compression plus the latent heat of vaporization from the evaporator is dissipated into the surrounding cooling medium.

17-12. The removal of heat causes the gas to condense to a high-pressure liquid. This liquid flows into a receiver, which is merely a storage space for the refrigerant. The liquid leaves the receiver and moves up the liquid line to the expansion valve, where the pressure of the liquid is reduced. As a result, it absorbs heat through the walls of the evaporator, lowering the temperature of the compartment to be cooled. As the liquid boils, which is caused by the heat picked up from the cooling compartment, it changes into a low-pressure gas. This low-pressure gas now enters the suction line leading to the compressor. The cycle is now complete.

17-13. **Absorption System.** The absorption system differs from a compression system in that heat energy is used instead of mechanical energy to make a change in the conditions necessary to complete a cycle of refrigeration. Gas, kerosene, or an electrical heating element is used as the source of heat supply.

17-14. To better explain the operation of the absorption system, we have put figure 68 in block form. Also we have added a float in the condenser. Let's start the cycle by creating a vacuum in the absorber and evaporator, and starting these pumps. Water will boil at 40° F.- 45° F. with a vacuum of 29.53 inches of mercury (Hg). As the refrigerant (water) is sprayed on the 55° F. chilled water coil, the refrigerant boils and absorbs the heat from the chilled water. The refrigerant vapor is then absorbed by the lithium bromide, and becomes weaker. To have continuous operations, the lithium bromide must be made stronger and the refrigerant must return to the evaporator. To do this the generator pump is started and a steam valve is opened. The generator pump forces the weak solution through the heat exchanger (where the weak solution is preheated and the strong solution from the generator is cooled), then into the generator. Steam is used to make the refrigerant (water) go into a vapor again where it condenses into pure water in the condenser. As the refrigerant level rises in the condenser the float opens to return the refrigerant into the evaporator for continuous operation.

17-15. We have discussed the physics of refrigeration and the cycle of the mechanical and absorption refrigeration systems. Now let's discuss the medium used in these systems to transfer the heat from where it is unwanted to a place where it is unobjectionable.

CHAPTER 3

Practice Exercises

Objective: To show knowledge of the physics of refrigeration and to apply the theory to the subtraction of heat.

1. At what temperature will all molecular movement stop? (16-2)
2. When a solid changes directly from a solid to a gas, what is it called? (16-3)
3. How is cold produced? (16-3)
4. Describe the term “sensible heat.” (16-4)
5. Describe the term “latent heat.” (16-5)
6. What is the specific heat of water? (16-7)

7. Convert -40° centigrade to Fahrenheit. (16-16)

8. How is the relative weight of liquids and solids determined? (16-18)

9. What is the pressure per square foot at sea level? (16-20)

10. What amount of work is done in lifting 33,000 pounds a distance of 2 feet in 1 minute? What the required horsepower? (16-23, 24)

11. What is 1 Btu equal to in foot-pounds? (16-25)

12. How many Btus are required to raise the temperature of 50 pounds of water 2° ? (16-26)

13. What is the temperature called at which a liquid cannot be liquefied regardless of the applied pressure? (16-28)

CHAPTER 4

Refrigerants

Heat cannot be transferred from the inside of the refrigerator to the outside without some sort of medium or heat-carrying device. This medium is called refrigerant.

2. Just what is refrigerant? Well, the dictionary defines it as follows, "A substance, such as ice, liquid air, ammonia, or carbon dioxide, used in refrigeration." We could define refrigerant as the medium (fluid or gas) used to transfer heat from the evaporator to the condenser.

3. The requirements for a refrigerant are almost self-explanatory. It is obvious that an automatic mechanism should be safe; that is, free from the danger of poisonous, flammable, or explosive gases. Refrigerants must be noncorrosive in order that the more common metal can be used in the construction of the machine part. It must also be such that its presence can be easily detected and traced to its source in the event of leaks. It is also desirable to keep pressures within the refrigeration cycle as close to atmospheric pressure as possible, for any great differences in pressures tend to cause leaks, overwork the compressor, and lower the overall efficiency of the system. Another desirable characteristic of a refrigerant is stability. If a refrigerant is to have this, then it must remain chemically unchanged while constantly going from a low temperature to a high temperature and back to a low temperature. It must not set up a chemical reaction with the lubricants used in the system. It must not chemically deteriorate if it comes in contact with air or moisture within the system.

4. There are various types of refrigerants used today. The choice depends upon the application. Each manufacturer attaches to his unit a nameplate which gives the type and amount of charge in the system. Changing to a different refrigerant should not even be considered, since most units are designed for use with one specific refrigerant. Each refrigerant has a different pressure-temperature relationship. This relationship will be the topic of our next discussion.

18. Effect of Temperature and Pressure

18-1. As you learned earlier, we can liquefy any gas by lowering its temperature. At some temperatures the gas can be liquefied by increasing the pressure. However, there are temperatures at which gases cannot be liquefied regardless of the applied pressure. These are called critical temperatures.

18-2. For example, we can change steam to water by lowering its temperature below 212° F. or raising the pressure; but at 689° F. no amount of pressure will effect the change. Anyone living at a high altitude has noticed that boiled food must be cooked for a longer period of time or under pressure. Boiling temperatures of points are lower at lower atmospheric pressures and higher at higher atmospheric pressures. The critical pressure of a gas (water vapor) is the minimum pressure required to liquefy (condense) it at its critical temperature.

18-3. The critical pressure of a refrigerant must be above any condensing pressure that might be encountered during a cycle of operation; otherwise the high-pressure gas would not condense and the refrigeration machine would cease functioning. If the ordinary condensing pressures are up near the critical pressure, the amount of power required to compress the refrigerant is excessive; therefore the critical pressure of a refrigerant must be well above the normal condensing pressure.

18-4. If the critical temperature of a refrigerant is not higher than the condensing temperature, the hot gas coming from the compressor will not condense regardless of pressure. If the temperature differential is small, power consumption is excessive.

18-5. If the hot gas coming from the compressor doesn't cool, the refrigeration cycle is not complete. The heat transferred to the refrigerant in the evaporator cannot be dissipated at the condenser. What heat was transferred in the evaporator? The heat from the food and inclosed area.

This caused the refrigerant to evaporate. Let's explain this heat and vaporization process thoroughly.

18-6. **Latent Heat of Vaporization.** With the exception of the comparatively small amount of heat absorbed by vapor superheated in the evaporator and in that part of the suction line within the refrigerator space, all of the heat-absorbing or refrigerating capacity that a refrigerant has comes from its latent heat of vaporization. In other words it depends on how much heat the refrigerant requires per pound to be changed from a liquid to a gas. Everything else being equal, the refrigerant having the highest latent heat of vaporization is the most desirable.

18-7. **Boiling Point and Condensing Temperature.** Each refrigerant is made up of a combination of chemical elements. The various components of each differ in reaching their boiling point or the temperature at which they condense. The boiling point of a refrigerant is that temperature and pressure at which it is changed from a low-pressure liquid to a low-pressure gas. The heat required comes from the area to be lowered in temperature. The evaporator is the heat-absorbing section of a system. As stated before, the refrigerant R-12 has a boiling point of -21.7° F. at atmospheric pressure. This boiling point is well below the lowest evaporating temperature at which the system operates.

18-8. The critical temperature of a refrigerant is usually considerably higher than the condensing temperature and pressure required in an operational system. The critical temperature of R-12 is 233° F., and the critical pressure is 582 pounds per square inch. The pressure temperature table for R-12, found in the appendix of this volume, will show the normal operating pressure corresponding to a given temperature. (Table 2)

18-9. The cooling medium, such as air or water, is cooler than the refrigerant as it enters the condenser. Heat is absorbed by the cooling medium and dissipated into the atmosphere which changes the state of the refrigerant from a gas to a liquid.

18-10. **Classification of Refrigerants.** Today there are a number of different refrigerants used by manufacturers of refrigeration machines. The following paragraphs are devoted to a discussion of a few different refrigerants, their characteristics, and the methods used in testing for leaks.

18-11. *Ammonia (NH_3).* This refrigerant is used most in certain applications in industry and also in the absorption type refrigerator. Ammonia is colorless and has a pungent odor. It boils at -28° F. atmospheric pressure. When one volume of ammonia and two volumes of air are mixed, there is danger of explosion. Ammonia very toxic and requires heavy fittings. Units using ammonia must be water cooled. To detect ammonia leaks, the repairman uses a sulphur candle, the flame of which gives off a white smoke when it comes in contact

with an ammonia vapor. Still another means of detecting an ammonia leak is the phenolphthalein paper method. A mild concentration of ammonia causes the paper to turn pink; heavier concentrations turn the paper scarlet. (Table 1)

8-12. *Refrigerant (R-12).* Refrigerant-12 is colorless and odorless both as a liquid and as a gas. If a heavy concentration of this gas is present, a very slight odor is evident, but the vapor will not irritate the skin, eyes, nose, or throat. R-12 boils at -21.7° under atmospheric pressure. The presence of moisture in R-12 does not cause corrosion; only a mild discoloration of brass, copper and steel results. It is noncombustible and also mixes readily with oil. To detect R-12 and other halogen refrigerant leaks the halide detector (as shown in fig. 69) may be used. Other methods may also be used.

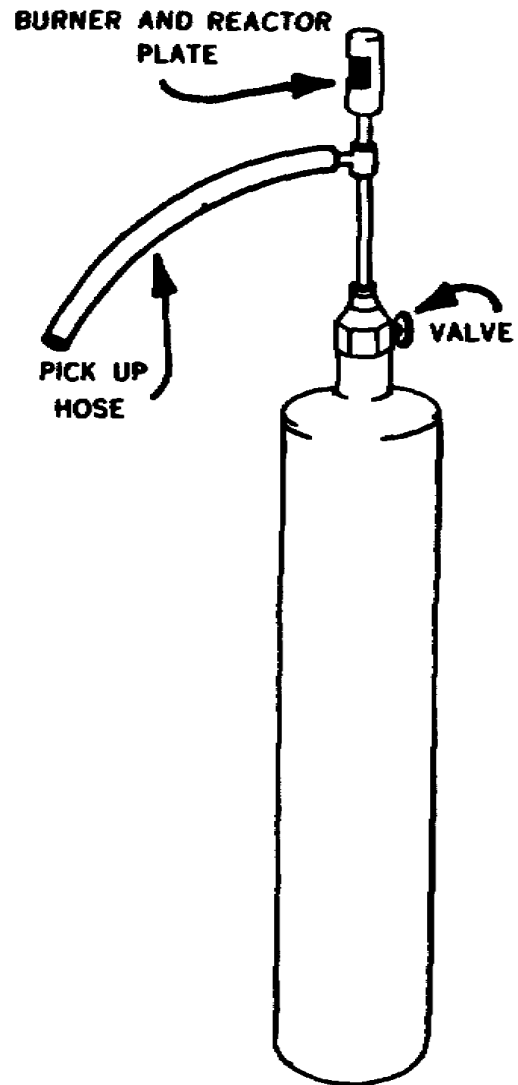

Figure 69. Halide leak detector.

18-13. *Carbon dioxide.* Carbon dioxide gas is harmless to breathe except, of course, in heavy concentrations when all the oxygen is excluded. In such cases, suffocation results. It has a slightly pungent odor and an acid taste.

18-14. Because of its low efficiency as compared to others, this refrigerant is seldom used in household refrigerators. It is used principally in industrial systems and on ships.

18-15. *Other refrigerants.* Other refrigerants used to a great extent in the refrigeration industry are Refrigerant-11, Refrigerant-22, and Refrigerant-11. Less commonly used refrigerants are Refrigerant-21, Refrigerant-113, butane, ethane, propane, and methyl formate. (Tables 3-5)

18-16. You must become familiar with the safety precautions related to refrigerants, for as we've mentioned previously, working safely benefits both the equipment and you.

18-17. **Transfer of Refrigerants.** Refrigerants are obtainable in amounts from railroad carload to a 1-pound can. However, most of the refrigerant is in 145-pound cylinders. These cylinders are too heavy for the serviceman to move from place to place so the refrigerant must be transferred into smaller containers. This is done by obtaining a small cylinder designed for the particular gas which is to be transferred. Connect a charging line, weigh the empty cylinder and cool it if possible (set in ice or other methods), invert the full cylinder, and open both cylinder valves. Stop the transfer when the small cylinder becomes 80-85 percent liquid full. CAUTION: Never fill a cylinder over 85 percent liquid full and always wear protective equipment when transferring refrigerant.

18-18. Let's look at some of the "do's" and "don'ts" while handling refrigerant cylinders.

(1) Never drop cylinders or permit them to strike each other violently.

(2) Never use a lifting magnet or a sling when handling cylinders. A crane may be used when a safe cradle or platform provided to hold the cylinders.

(3) Cylinder valve caps should be kept on at all times except when the cylinders are in use.

(4) Never fill a refrigerant cylinder completely full of refrigerant. The safe limit is 85 percent full. Overfilled cylinders are apt to burst from hydrostatic pressure.

(5) Never mix gases in a cylinder.

(6) Cylinders are made to hold gas - don't use them for a support or roller.

(7) Never tamper with the safety device on a cylinder.

(8) Open cylinder valves slowly and use a

cylinder valve wrench. Never use a monkey or Stillson wrench for this purpose.

(9) Never force misfitting connections; make sure that the threads of regulators and unions are the same as those on the cylinder outlet.

(10) Never attempt to repair or alter a cylinder or valves.

(11) Never store cylinders near flammables.

(12) Always keep cylinders in a cool place away from direct sun rays if possible and fully secured in place.

(13) Do not store full and empty refrigerant cylinders together. They should be stored in different sections of the shop to avoid confusion.

(14) Always insure that gas cylinders are secured in place both when empty and filled.

18-19. As we stated before, you should always wear protective equipment while charging or transferring refrigerant. However, if something happens when you do not have the protective equipment on and the refrigerant comes in contact with your eyes or skin, you should know the first aid that will help you. If the refrigerant comes in contact with the eyes they can be bathed in a 2-percent boric acid solution. For frostbite on the skin the area can be bathed with cold water and massaged around the area until circulation is restored. Do not disturb the frost blisters.

18-20. A refrigerant is the carrier of heat in a system; consequently, it is found in different parts of the system in different states. How do we know which state the refrigerant is in within the system? Very easy; we use the refrigerant table. Using the table, we can check the pressures within the system and convert the pressures to temperatures. This can also tell us if the system is safe to open. Remember, even though you know a little first aid, it's better to be safe than sorry.

18-21. Tables have been compiled through experiment and research for each of the most commonly used refrigerants. These tables show the pressure, density, volume, heat content, and latent heat corresponding to certain temperatures. The charts are so designed that when you have one condition given you can determine the other relative factors. (Tables 1-6)

18-22. We have had a discussion on a few of the most important refrigerants and their purpose as heat carriers in a refrigeration system. A refrigerant is the bloodstream of any refrigerator; it removes heat at a low pressure as it evaporates, and gives up heat at a high pressure as it condenses. The properties of a few of the most common refrigerant gases are discussed and the characteristics noted, as well as the safety precautions which are essential and must be observed. You are the one who will be handling refrigerant, so don't be careless, for they can

cause personal injury. The sections covering safety precautions, safe handling of gases, and first aid treatment list the “dos” and “don'ts” to be followed when dealing with refrigerants. Read and heed; these are for your own

benefit. Tables which will be used in every step of this course are contained in the appendix to this memorandum.

CHAPTER 4

Practice Exercise

Objective: To show knowledge of the characteristic of refrigerants and of safety practices in handling these refrigerants.

1. What is the critical temperature of water? (18-2)
2. Why must the critical pressure be above the condensing pressures? (18-3)
3. Which refrigerant would be the most desirable - one with the lowest or highest latent heat of vaporization? (18-6)
4. What kind of a refrigerant gives off a white smoke when a leak is detected while using a sulphur candle? (18-11)
5. What is the safe limit for filling a refrigerant cylinder? (18-17, 18)
6. If refrigerant comes in contact with the eyes, they may be bathed in what? (18-19)

Glossary

- ABSOLUTE HUMIDITY - The amount of moisture that is in the air; it is measured in grains per cubic foot.
- ABSOLUTE PRESSURE - Gage pressure plus atmospheric pressure (see pressure conversion table).
- ABSOLUTE TEMPERATURE - The temperature that is measured from absolute zero (-460° F., zero° R., and -273° C., zero° K.)
- ACCUMULATOR - A tank that is used to keep liquid refrigerant from flowing to the compressor.
- ACTIVATED ALUMINA - A chemical desiccant.
- ACTIVATED CARBON - Processed carbon that is used for a filter.
- ADIABATIC COOLING - Process of changing sensible heat for latent heat without removing heat (evaporative cooling).
- ANEMOMETER - An instrument used to measure the rate of airflow.
- ATMOSPHERIC PRESSURE - Pressure that is exerted upon the earth by the atmospheric gases.
- AUTOTRANSFER - Common turns serve both the primary and secondary coils. Different taps are used to step up or step down the voltage.
- AZEOTROPIC REFRIGERANTS - These are mixtures of refrigerants that do not combine chemically but provide good refrigerant characteristics.
- BACK PRESSURE - Low side pressure or suction pressure.
- BOYLE'S LAW - The volume of a given mass of gas varies as the pressure varies if the temperature remains the same.
- BRITISH THERMAL UNIT - The amount of heat required to raise the temperature of 1 pound of water 1° F.
- CALORIE - The quantity of heat required to raise the temperature of 1 gram of water 1° C.
- CASCADE SYSTEM - Refrigeration system where two or more systems are connected in series to produce ultra-low temperatures.
- CHARLES' LAW - The volume of a gas varies directly with the temperature provided that the pressure remains constant.
- COEFFICIENT OF PERFORMANCE (COP) - The ratio of energy applied as compared to the energy used.
- COMPOUND REFRIGERATION SYSTEM - A system with two or more compressors or cylinders in series.
- CRITICAL PRESSURE - The pressure of the saturated vapor at the critical temperature.
- CRITICAL TEMPERATURE - The temperature at which the liquid and vapor densities of a substance become equal.
- CROSS CHARGED - Two different fluids used to create the desired pressure-temperature relationship.
- CRYOGENIC FLUID - An ultra-low temperature gas or liquid.
- CRYOGENICS - Refrigeration producing temperatures at or below -250° F.
- CURRENT RELAY - A relay which makes or breaks a circuit depending on a change in current flow.
- DALTON'S LAW - The total pressure of a mixture of gases is the sum of the partial pressures of each of the gases in the mixture.

DENSITY - The mass of a substance per unit volume (consistency).

DEWPOINT - The temperature at which a saturated vapor will begin to condense.

DRY ICE - Solid carbon dioxide at approximately -109°F .; it is used in the shipment of produce.

EBULATOR - A sharp-edged material inserted in a flooded evaporator for better efficiency.

FLASH GAS - When changing from a high-pressure liquid to a low-pressure liquid some of the liquid flashes (evaporates) off and cools the remaining liquid to the desired evaporation temperature.

FOOT-POUND - The amount of work done in lifting 1 pound 1 foot.

GRAIN - A unit of weight; 7000 grains equals 1 pound.

HEAD, STATIC - Pressure of a fluid measured in terms of height of the column of the fluid.

HEAT LOAD - The Btus that are removed in 24 hours.

HEAT OF COMPRESSION - The transformation of mechanical energy of pressure into energy of heat.

HYDROMETER - An instrument used to measure the specific gravity of a liquid.

HYGROMETER - An instrument used to measure the ratio of moisture in the air.

INDUCTION MOTOR - An ac motor that operates on the principles of a rotating magnetic field.

KATATHERMOMETER - An alcohol thermometer used to measure air velocities by means of cooling effect.

KELVIN SCALE (K) - A thermometer scale that is equal to centigrade but using zero as absolute zero instead of -273°C . (absolute centigrade).

LATENT HEAT - Hidden heat; heat energy that a substance absorbs while changing state.

MANOMETER - A U-shaped tube filled with a liquid that is used to measure the pressure of gases and vapors.

MEGOHM - One million ohms.

MULLION HEATER - An electrical heating element used to keep the stationary part (mullion) of the structure between the doors from sweating or frosting.

MULTIPLE EVAPORATION SYSTEM - A system with two or more evaporators connected in parallel.

MULTIPLE SYSTEM - A system with two or more evaporators connected to one condensing unit.

OIL SEPARATOR - A device used to remove oil from a gaseous refrigerant.

OZONE - A gaseous form of oxygen, usually generated by a silent electrical discharge in ordinary air.

PITOT TUBE - Part of an instrument used to measure air velocities.

POTENTIAL ELECTRICAL - The electrical force which tries to move or moves the electrons in a circuit.

POTENTIAL RELAY - A relay which is operated by voltage changes in an electromagnet.

POWER FACTOR - Correction coefficient for ac power.

PYROMETER - A device used to measure high temperatures.

RANKIN SCALE (R) - A thermometer scale that is equal to Fahrenheit but using zero as absolute zero instead of -460°F . (absolute Fahrenheit).

RELATIVE HUMIDITY - The percent of moisture in the air as to what it can hold at that temperature and pressure.

SATURATION - When air is saturated it is holding the maximum amount of water vapor at that temperature and pressure. (It may also be applied to other substances.)

SENSIBLE HEAT - Heat that can be measured and causes a change in temperature.

SOLAR HEAT - Heat energy waves of the sun.

SPECIFIC GRAVITY - Weight of a liquid compared to water.

SPECIFIC HEAT - The ratio of the quantity of heat required to raise the temperature of a body or mass 1° to that required to raise the temperature of an equal mass of water 1°.

SPECIFIC VOLUME - Volume per unit (one) mass of a substance.

STANDARD ATMOSPHERE - When air is at a condition of 14.7 psia and 68° F.

STANDARD CONDITIONS - 68° F., 29.92 inches Hg., and R. H. of 30 percent used in air-conditioning calculations.

STRATIFICATION OF AIR - When air lies in different temperature layers because of little or no air movement.

SUBLIMATION - When a substance changes from a solid directly into a gas without becoming a liquid.

SUBCOOLING - Cooling of a liquid below its condensing temperature.

SUPERHEAT - Adding heat to a vapor above its boiling temperature and at the same pressure.

THERM - 100,000 British thermal units.

THERMISTORS - An electrical resistor made of a material whose resistance varies with the temperature.

TRANSISTOR - An electrical device used to transfer an electrical signal across a resistor.

TRIPLE POINT - A condition of pressure and temperature where the liquid, vapor, and solid states can coexist.

VAPOR PRESSURE - The pressure exerted by a vapor upon its liquid or solid form.

VELOCIMETER - A direct reading air velocity meter, reading in feet per minute.

WEB BULB - A dry bulb thermometer with a wick attached to the bulb that is used in the measurement of relative humidity.

APPENDIX

REFRIGERANTS

Properties of Liquid and Saturated Vapor

Tables 1 - 6

TABLE 1
AMMONIA—PROPERTIES OF LIQUID AND SATURATED VAPOR

Temp F	Pressure		Liquid, density lb/cu ft 1/2	Vapor, sp vol cu ft/lb 2	Enthalpy, datum - 40 F Btu per lb		Entropy, datum - 40 F Btu per lb F	
	psia	psig			Liquid h _f	Vapor h _g	Liquid s _f	Vapor s _g
-105	1.00	27.9	45.71	223.14	-66.6	569.1	-0.1717	1.6311
-104	1.04	27.8	45.67	214.23	-66.6	569.6	-0.1699	1.6174
-103	1.08	27.7	45.63	205.90	-66.5	570.1	-0.1681	1.6136
-102	1.14	27.7	45.59	197.70	-66.5	570.6	-0.1664	1.6100
-101	1.19	27.5	45.55	190.08	-66.5	571.0	-0.1646	1.6063
-100	1.24	27.4	45.51	182.90	-61.5	571.4	-0.1579	1.6025
-99	1.29	27.3	45.47	175.42	-60.5	571.9	-0.1552	1.5988
-98	1.35	27.2	45.43	168.48	-59.5	572.3	-0.1525	1.5952
-97	1.41	27.0	45.40	161.98	-58.5	572.7	-0.1498	1.5915
-96	1.47	26.9	45.36	155.92	-57.5	573.2	-0.1471	1.5878
-95	1.53	26.8	45.32	150.30	-56.5	573.6	-0.1444	1.5842
-94	1.59	26.7	45.28	144.68	-55.5	574.1	-0.1417	1.5805
-93	1.65	26.5	45.24	139.27	-54.5	574.5	-0.1390	1.5771
-92	1.73	26.4	45.20	134.06	-53.4	575.0	-0.1363	1.5736
-91	1.79	26.2	45.16	129.06	-52.4	575.5	-0.1336	1.5702
-90	1.85	26.1	45.12	124.28	-51.4	575.9	-0.1309	1.5667
-89	1.94	26.0	45.08	119.73	-50.4	576.3	-0.1282	1.5633
-88	2.02	25.8	45.04	115.37	-49.4	576.7	-0.1254	1.5600
-87	2.11	25.6	45.00	111.21	-48.4	577.2	-0.1227	1.5566
-86	2.18	25.5	44.96	107.29	-47.4	577.6	-0.1199	1.5533
-85	2.27	25.3	44.92	103.63	-46.4	578.0	-0.1171	1.5500
-84	2.36	25.1	44.88	99.97	-45.4	578.4	-0.1144	1.5466
-83	2.46	24.9	44.84	96.29	-44.3	578.9	-0.1117	1.5433
-82	2.55	24.7	44.80	92.86	-43.3	579.3	-0.1090	1.5401
-81	2.65	24.5	44.76	89.65	-42.3	579.7	-0.1063	1.5368
-80	2.74	24.3	44.73	86.54	-41.3	580.1	-0.1036	1.5336
-79	2.85	24.1	44.68	83.50	-40.3	580.5	-0.1009	1.5304
-78	2.96	23.9	44.64	80.61	-39.2	581.0	-0.0983	1.5273
-77	3.07	23.6	44.60	77.90	-38.2	581.4	-0.0956	1.5241
-76	3.19	23.4	44.56	75.30	-37.2	581.8	-0.0930	1.5210
-75	3.30	23.2	44.52	72.80	-36.2	582.2	-0.0903	1.5178
-74	3.43	22.9	44.48	70.35	-35.2	582.7	-0.0877	1.5146
-73	3.56	22.7	44.44	68.01	-34.2	583.1	-0.0850	1.5117
-72	3.69	22.4	44.40	65.78	-33.1	583.6	-0.0824	1.5087
-71	3.83	22.2	44.36	63.70	-32.1	584.0	-0.0797	1.5056
-70	3.96	21.9	44.32	61.65	-31.1	584.4	-0.0771	1.5026
-69	4.09	21.6	44.28	59.60	-30.1	584.8	-0.0745	1.4997
-68	4.24	21.3	44.24	57.64	-29.4	585.3	-0.0719	1.4968
-67	4.39	21.0	44.19	55.78	-28.6	585.8	-0.0694	1.4940
-66	4.54	20.7	44.15	54.01	-27.0	586.2	-0.0668	1.4911
-65	4.69	20.4	44.11	52.34	-26.0	586.6	-0.0642	1.4883
-64	4.85	20.1	44.07	50.70	-25.0	587.0	-0.0616	1.4855
-63	5.02	19.6	44.03	49.26	-23.9	587.5	-0.0590	1.4829
-62	5.20	19.3	43.99	47.74	-22.9	588.0	-0.0565	1.4803
-61	5.38	18.9	43.95	46.23	-21.9	588.4	-0.0539	1.4774
-60	5.55	18.6	43.91	44.73	-20.9	588.8	-0.0514	1.4747
-59	5.74	18.2	43.87	43.37	-19.8	589.3	-0.0487	1.4720
-58	5.93	17.8	43.83	42.05	-18.8	589.7	-0.0460	1.4694
-57	6.13	17.4	43.78	40.79	-17.8	590.2	-0.0434	1.4667
-56	6.33	17.0	43.74	39.56	-16.7	590.6	-0.0407	1.4640
-55	6.54	16.6	43.70	38.38	-15.7	591.0	-0.0381	1.4614
-54	6.75	16.2	43.66	37.24	-14.6	591.5	-0.0355	1.4588
-53	6.97	15.7	43.62	36.15	-13.6	591.9	-0.0330	1.4563
-52	7.20	15.3	43.58	35.09	-12.6	592.3	-0.0305	1.4537
-51	7.43	14.8	43.54	34.06	-11.5	592.8	-0.0279	1.4513
-50	7.67	14.3	43.49	33.05	-10.5	593.2	-0.0254	1.4487
-49	7.91	13.8	43.45	32.12	-9.4	593.7	-0.0229	1.4463
-48	8.16	13.3	43.41	31.20	-8.4	594.2	-0.0203	1.4438
-47	8.42	12.8	43.37	30.31	-7.3	594.6	-0.0178	1.4413
-46	8.68	12.2	43.33	29.45	-6.3	595.0	-0.0153	1.4388
-45	8.95	11.7	43.28	28.62	-5.3	595.4	-0.0128	1.4363
-44	9.23	11.1	43.24	27.82	-4.3	595.9	-0.0102	1.4338
-43	9.51	10.6	43.20	27.04	-3.2	596.4	-0.0076	1.4314
-42	9.81	10.0	43.16	26.29	-2.1	596.8	-0.0051	1.4290
-41	10.10	9.3	43.12	25.56	-1.1	597.2	-0.0025	1.4266

* Inches of mercury below one standard atmosphere (29.92 in.).

TABLE 1 (cont'd)

Temp °F	Pressure		Liquid, density	Vapor, sp vol	Enthalpy, datum - 40°F Btu per lb		Entropy, datum - 40°F Btu per lb F	
	psia	psig	lb/cu ft l/v _l	cu ft/lb v _g	Liquid h _l	Vapor h _g	Liquid s _l	Vapor s _g
- 40	10.41	0.7	43.08	24.86	0.0	397.6	0.0000	1.4242
- 39	10.72	1.1	43.04	24.18	1.1	398.0	.0023	1.4217
- 38	11.04	1.4	42.99	23.53	2.1	398.3	.0051	1.4193
- 37	11.37	1.8	42.95	22.89	3.2	398.7	.0076	1.4169
- 36	11.71	2.1	42.90	22.27	4.3	399.1	.0101	1.4144
- 35	12.05	2.5	42.86	21.66	5.3	399.5	0.0126	1.4120
- 34	12.41	2.9	42.82	21.10	6.4	399.9	.0151	1.4096
- 33	12.77	3.3	42.78	20.54	7.4	400.2	.0176	1.4072
- 32	13.14	3.7	42.73	20.00	8.5	400.6	.0201	1.4048
- 31	13.52	4.1	42.69	19.48	9.6	401.0	.0226	1.4025
- 30	13.90	4.5	42.65	18.97	10.7	401.4	0.0250	1.4001
- 29	14.29	4.9	42.61	18.48	11.7	401.7	.0275	1.3978
- 28	14.71	5.3	42.57	18.00	12.8	402.1	.0300	1.3955
- 27	15.12	5.7	42.54	17.54	13.9	402.5	.0325	1.3932
- 26	15.55	6.1	42.50	17.09	14.9	402.8	.0350	1.3909
- 25	15.98	6.5	42.46	16.66	16.0	403.2	0.0374	1.3886
- 24	16.42	6.9	42.42	16.24	17.1	403.6	.0399	1.3863
- 23	16.86	7.3	42.38	15.83	18.1	403.9	.0423	1.3840
- 22	17.31	7.7	42.34	15.43	19.2	404.3	.0448	1.3818
- 21	17.77	8.1	42.30	15.05	20.3	404.6	.0472	1.3796
- 20	18.23	8.5	42.26	14.68	21.4	405.0	0.0497	1.3774
- 19	18.70	8.9	42.22	14.32	22.4	405.3	.0521	1.3752
- 18	19.17	9.3	42.18	13.97	23.5	405.7	.0545	1.3729
- 17	19.65	9.7	42.14	13.62	24.6	406.1	.0570	1.3706
- 16	20.13	10.1	42.10	13.29	25.6	406.4	.0594	1.3684
- 15	20.62	10.5	42.06	12.97	26.7	406.7	0.0618	1.3664
- 14	21.11	10.9	42.02	12.66	27.8	407.1	.0642	1.3643
- 13	21.60	11.3	41.98	12.36	28.9	407.5	.0666	1.3621
- 12	22.10	11.7	41.94	12.06	30.0	407.8	.0690	1.3600
- 11	22.60	12.1	41.90	11.78	31.0	408.1	.0714	1.3579
- 10	23.10	12.5	41.86	11.50	32.1	408.5	0.0738	1.3558
- 9	23.60	12.9	41.82	11.23	33.2	408.8	.0762	1.3537
- 8	24.10	13.3	41.78	10.97	34.3	409.2	.0786	1.3516
- 7	24.60	13.7	41.74	10.71	35.4	409.5	.0810	1.3495
- 6	25.10	14.1	41.70	10.47	36.4	409.8	.0833	1.3474
- 5	25.60	14.5	41.66	10.23	37.5	410.1	0.0857	1.3454
- 4	26.10	14.9	41.62	9.991	38.6	410.5	.0880	1.3433
- 3	26.60	15.3	41.58	9.763	39.7	410.8	.0904	1.3413
- 2	27.10	15.7	41.54	9.541	40.7	411.1	.0928	1.3393
- 1	27.60	16.1	41.50	9.326	41.8	411.4	.0951	1.3372
0	28.10	16.5	41.46	9.116	42.9	411.8	0.0975	1.3352
1	28.60	16.9	41.42	8.912	44.0	412.1	0.0998	1.3332
2	29.10	17.3	41.38	8.714	45.1	412.4	.1022	1.3312
3	29.60	17.7	41.34	8.521	46.2	412.7	.1045	1.3292
4	30.10	18.1	41.30	8.333	47.2	413.0	.1069	1.3272
5	30.60	18.5	41.26	8.150	48.3	413.3	.1092	1.3253
6	31.10	18.9	41.22	7.971	49.4	413.6	0.1115	1.3234
7	31.60	19.3	41.18	7.796	50.5	413.9	.1138	1.3214
8	32.10	19.7	41.14	7.629	51.6	414.3	.1162	1.3195
9	32.60	20.1	41.10	7.464	52.7	414.6	.1185	1.3176
10	33.10	20.5	41.06	7.304	53.8	414.9	.1208	1.3157
11	33.60	20.9	41.02	7.148	54.9	415.2	0.1231	1.3137
12	34.10	21.3	40.98	6.996	56.0	415.5	.1254	1.3118
13	34.60	21.7	40.94	6.847	57.1	415.8	.1277	1.3099
14	35.10	22.1	40.90	6.703	58.2	416.1	.1300	1.3081
15	35.60	22.5	40.86	6.562	59.2	416.3	.1323	1.3062
16	36.10	22.9	40.82	6.425	60.3	416.6	0.1346	1.3043
17	36.60	23.3	40.78	6.291	61.4	416.9	.1369	1.3025
18	37.10	23.7	40.74	6.161	62.5	417.2	.1392	1.3006
19	37.60	24.1	40.70	6.034	63.6	417.5	.1415	1.2988
20	38.10	24.5	40.66	5.910	64.7	417.8	.1437	1.2969
21	38.60	24.9	40.62	5.789	65.8	418.0	0.1460	1.2951
22	39.10	25.3	40.58	5.671	66.9	418.3	.1483	1.2933
23	39.60	25.7	40.54	5.556	68.0	418.6	.1506	1.2915
24	40.10	26.1	40.50	5.443	69.1	418.9	.1528	1.2897
25	40.60	26.5	40.46	5.334	70.2	419.1	.1551	1.2879

* Inches of mercury below one standard atmosphere (30.00 in.).

TABLE I (cont'd)

Temp F t	Pressure		Liquid, density	Vapor, sp vol	Enthalpy, datum Btu per lb		Entropy, datum --60 F Btu per lb F	
	psia	psig	lb/cu ft l/ft ³	cu ft/lb v _g	Liquid h _f	Vapor h _g	Liquid s _f	Vapor s _g
26	54.90	40.2	40.15	5.227	71.3	619.4	0.1573	1.2861
27	56.08	41.4	40.10	5.123	72.4	619.7	.1596	1.2843
28	57.28	42.6	40.05	5.021	73.5	619.9	.1618	1.2825
29	58.50	43.8	40.01	4.922	74.6	620.2	.1641	1.2808
30	59.74	45.0	39.96	4.825	75.7	620.5	.1663	1.2790
31	61.00	46.3	39.91	4.730	76.8	620.7	0.1686	1.2773
32	62.29	47.6	39.86	4.637	77.9	621.0	.1708	1.2755
33	63.59	48.9	39.82	4.547	79.0	621.2	.1730	1.2738
34	64.91	50.2	39.77	4.459	80.1	621.5	.1753	1.2731
35	66.26	52.6	39.72	4.373	81.2	621.7	.1775	1.2704
36	67.63	52.9	39.67	4.289	82.3	622.0	0.1797	1.2686
37	69.02	54.3	39.63	4.207	83.4	622.2	.1819	1.2669
38	70.43	55.7	39.58	4.126	84.6	622.5	.1841	1.2652
39	71.87	57.2	39.54	4.046	85.7	622.7	.1863	1.2635
40	73.32	58.6	39.49	3.971	86.8	623.0	.1885	1.2618
41	74.80	60.1	39.44	3.897	87.9	623.2	0.1908	1.2602
42	76.31	61.6	39.39	3.823	89.0	623.4	.1930	1.2585
43	77.83	63.1	39.34	3.752	90.1	623.7	.1952	1.2568
44	79.38	64.7	39.29	3.682	91.2	623.9	.1974	1.2552
45	80.95	66.3	39.24	3.614	92.3	624.1	.1996	1.2535
46	82.55	67.9	39.19	3.547	93.5	624.4	0.2018	1.2519
47	84.18	69.5	39.15	3.481	94.6	624.6	.2040	1.2503
48	85.82	71.1	39.10	3.418	95.7	624.8	.2062	1.2486
49	87.49	72.8	39.05	3.355	96.8	625.0	.2083	1.2469
50	89.19	74.5	39.00	3.294	97.9	625.2	.2105	1.2453
51	90.91	76.2	38.95	3.234	99.1	625.5	0.2127	1.2437
52	92.66	78.0	38.90	3.176	100.2	625.7	.2149	1.2421
53	94.43	79.7	38.85	3.119	101.3	625.9	.2171	1.2405
54	96.23	81.5	38.80	3.063	102.4	626.1	.2192	1.2389
55	98.06	83.4	38.75	3.008	103.5	626.3	.2214	1.2373
56	99.91	85.2	38.70	2.954	104.7	626.5	0.2236	1.2357
57	101.8	87.1	38.65	2.902	105.8	626.7	.2257	1.2341
58	103.7	89.0	38.60	2.851	106.9	626.9	.2279	1.2325
59	105.6	90.9	38.55	2.800	108.1	627.1	.2301	1.2310
60	107.6	92.9	38.50	2.751	109.2	627.3	.2322	1.2294
61	109.6	94.9	38.45	2.703	110.3	627.5	0.2344	1.2278
62	111.6	96.9	38.40	2.656	111.5	627.7	.2365	1.2262
63	113.6	98.9	38.35	2.610	112.6	627.9	.2387	1.2247
64	115.7	101.0	38.30	2.565	113.7	628.0	.2408	1.2231
65	117.8	103.1	38.25	2.520	114.8	628.2	.2430	1.2216
66	120.0	105.3	38.20	2.477	116.0	628.4	0.2451	1.2201
67	122.1	107.4	38.15	2.435	117.1	628.6	.2473	1.2185
68	124.3	109.6	38.10	2.393	118.3	628.8	.2494	1.2170
69	126.5	111.8	38.05	2.352	119.4	628.9	.2515	1.2155
70	128.8	114.1	38.00	2.312	120.5	629.1	.2537	1.2140
71	131.1	116.4	37.95	2.273	121.7	629.3	0.2558	1.2125
72	133.4	118.7	37.90	2.235	122.8	629.4	.2579	1.2110
73	135.7	121.0	37.84	2.197	124.0	629.5	.2601	1.2095
74	138.1	123.4	37.79	2.161	125.1	629.8	.2623	1.2080
75	140.5	125.8	37.74	2.125	126.2	629.9	.2645	1.2065
76	143.0	128.3	37.69	2.089	127.4	630.1	0.2664	1.2050
77	145.4	130.7	37.64	2.055	128.5	630.2	.2685	1.2035
78	147.9	133.2	37.58	2.021	129.7	630.4	.2705	1.2020
79	150.5	135.8	37.53	1.988	130.8	630.5	.2728	1.2006
80	153.0	138.3	37.48	1.955	132.0	630.7	.2749	1.1991
81	155.6	140.9	37.43	1.923	133.1	630.8	0.2769	1.1976
82	158.3	143.6	37.37	1.892	134.3	631.0	.2791	1.1962
83	161.0	146.3	37.32	1.861	135.4	631.1	.2812	1.1947
84	163.6	149.0	37.26	1.831	136.6	631.3	.2833	1.1933
85	166.4	151.7	37.21	1.801	137.8	631.4	.2854	1.1918
86	169.2	154.5	37.16	1.772	138.9	631.5	0.2875	1.1904
87	172.0	157.3	37.11	1.744	140.1	631.7	.2895	1.1889
88	174.8	160.1	37.05	1.716	141.2	631.8	.2917	1.1875
89	177.7	163.0	37.00	1.688	142.4	631.9	.2937	1.1860
90	180.6	165.9	36.95	1.661	143.5	632.0	.2958	1.1846

TABLE 1 (cont'd)

Temp F t	Pressure		Liquid, density	Vapor, sp vol	Enthalpy, datum - 40 F Btu per lb		Entropy, datum - 40 F Btu per lb F	
	psia	psig	lb/cu ft l/w	cu ft/lb w	Liquid h _f	Vapor h _g	Liquid s _f	Vapor s _g
91	183.6	168.9	35.89	1.633	144.7	632.1	0.3979	1.1832
92	186.6	171.9	35.84	1.609	145.8	632.3	.3990	1.1818
93	189.6	174.9	35.78	1.584	147.0	632.3	.3991	1.1804
94	192.7	178.0	35.73	1.559	148.2	632.5	.3991	1.1789
95	195.8	181.1	35.67	1.534	149.4	632.6	.3992	1.1775
96	198.9	184.2	35.62	1.510	150.5	632.6	0.3993	1.1761
97	202.1	187.4	35.56	1.487	151.7	632.8	.3994	1.1747
98	205.3	190.6	35.51	1.464	152.9	632.9	.3995	1.1733
99	208.6	193.9	35.45	1.441	154.0	632.9	.3995	1.1719
100	211.9	197.2	35.40	1.419	155.2	633.0	.3996	1.1705
101	215.2	200.5	35.34	1.397	156.4	633.1	0.3997	1.1691
102	218.6	203.9	35.29	1.375	157.6	633.2	.3997	1.1677
103	222.0	207.3	35.23	1.354	158.7	633.3	.3998	1.1663
104	224.4	210.7	35.18	1.334	159.9	633.4	.3998	1.1649
105	228.9	214.2	35.12	1.313	161.1	633.4	.3999	1.1635
106	232.5	217.8	35.06	1.293	162.3	633.5	0.3999	1.1621
107	236.0	221.3	35.01	1.274	163.5	633.6	.3999	1.1607
108	239.7	225.0	35.95	1.254	164.6	633.6	.3999	1.1593
109	243.3	228.6	35.90	1.235	165.8	633.7	.3999	1.1580
110	247.0	232.3	35.84	1.217	167.0	633.7	.3999	1.1566
111	250.8	236.1	35.78	1.198	168.2	633.8	0.3999	1.1552
112	254.5	239.8	35.72	1.180	169.4	633.8	.3999	1.1538
113	258.4	243.7	35.67	1.163	170.6	633.9	.3999	1.1524
114	262.2	247.5	35.61	1.146	171.8	633.9	.3999	1.1510
115	266.2	251.5	35.55	1.128	173.0	633.9	.3999	1.1497
116	270.1	255.4	35.49	1.112	174.2	634.0	0.3999	1.1483
117	274.1	259.4	35.43	1.095	175.4	634.0	.3999	1.1469
118	278.2	263.5	35.38	1.079	176.6	634.0	.3999	1.1455
119	282.3	267.6	35.32	1.063	177.8	634.0	.3999	1.1441
120	286.4	271.7	35.26	1.047	179.0	634.0	.3999	1.1427
121	290.6	275.9	35.20	1.032	180.2	634.0	0.3997	1.1414
122	294.8	280.1	35.14	1.017	181.4	634.0	.3998	1.1400
123	299.1	284.4	35.08	1.002	182.6	634.0	.3998	1.1386
124	303.4	288.7	35.02	0.987	183.9	634.0	.3998	1.1372
125	307.8	293.1	34.96	0.973	185.1	634.0	.3979	1.1358

Taken from ASRE DATA BOOK, 1951 Edition, and reprinted by permission of the American Society of Refrigerating Engineers.

TABLE 2 (cont'd)

Temp F	Pressure		Volume cu ft/lb	Density lb/cu ft	Enthalpy** Btu/lb		Entropy** Btu/(lb) (°R)		Temp F	Pressure		Volume cu ft/lb	Density lb/cu ft	Enthalpy** Btu/lb		Entropy** Btu/(lb) (°R)																	
	psia	psig	Vapor v _g	Liquid 1/v _f	Liquid h _f	Vapor h _g	Liquid s _f	Vapor s _g		psia	psig	Vapor v _g	Liquid 1/v _f	Liquid h _f	Vapor h _g	Liquid s _f	Vapor s _g																
105	141	25	126	55	0	28701	78	088	32	310	87	442	0	065339	0	16297	125	183	76	169	06	0	21791	75	145	37	275	88	973	0	073800	0	16222
106	143	18	128	48	28303	77	946	32	553	87	523	065761	16293	128	186	10	171	40	21497	74	991	37	829	89	044	074225	16218						
107	145	13	130	43	27910	77	804	32	797	87	604	066194	16290	127	188	47	173	77	21207	74	836	37	785	89	115	074630	16214						
108	147	11	132	41	27524	77	662	33	041	87	684	066606	16286	128	190	86	176	16	20922	74	680	38	040	89	184	075075	16210						
109	149	10	134	40	27143	77	519	33	286	87	764	067028	16282	129	193	27	178	57	20641	74	524	38	296	89	253	075501	16208						
110	151	11	136	41	0	26769	77	376	33	531	87	844	0	067481	0	16279	130	195	71	181	01	0	20364	74	367	38	533	89	321	0	075927	0	16202
111	153	14	138	44	26400	77	231	33	777	87	923	067873	16276	132	200	64	185	94	19821	74	050	39	069	89	456	076779	16194						
112	155	19	140	49	26037	77	087	34	023	88	001	068296	16271	134	205	67	190	97	19294	73	729	39	588	89	588	077633	16185						
113	157	27	142	57	25680	76	941	34	270	88	079	068719	16268	136	210	79	196	09	18782	73	406	40	110	89	718	078489	16177						
114	159	36	144	66	25328	76	795	34	517	88	156	069141	16264	138	216	01	201	31	18283	73	079	40	634	89	844	079346	16168						
115	161	47	146	77	0	24962	76	649	34	765	88	233	0	069564	0	16260	140	221	32	206	62	0	17799	72	748	41	162	89	987	0	080205	0	16150
116	163	61	148	91	24641	76	501	35	014	88	310	069987	16256	180	249	31	234	61	15564	71	035	43	850	90	534	084531	16110						
117	165	76	151	06	24304	76	353	35	263	88	386	070410	16253	160	279	82	265	12	13604	69	209	46	633	91	006	088927	16053						
118	167	94	153	24	23974	76	205	35	512	88	461	070833	16249	170	313	00	296	30	11873	67	244	49	329	91	359	093418	15985						
119	170	13	155	43	23647	76	056	35	762	88	536	071267	16245	180	349	00	334	30	10330	65	102	52	562	91	561	096039	15900						
120	172	35	157	65	0	23326	75	906	36	013	88	610	0	071680	0	16241	190	387	98	373	28	0	089418	62	728	55	769	91	561	0	10284	0	15793
121	174	59	159	89	23010	75	755	36	264	88	684	072104	16237	200	430	09	415	39	076728	60	026	59	203	91	378	10789	15651						
122	176	85	162	15	22696	75	604	36	516	88	757	072528	16234	210	475	52	440	82	064843	58	816	62	959	90	558	11332	15483						
123	179	13	164	43	22391	75	452	36	768	88	830	072962	16230	220	524	43	509	73	053140	52	670	67	246	89	036	11943	15149						
124	181	43	166	73	22069	75	299	37	021	88	902	073378	16226	233	596	9	582	2	02670	34	84	78	86	78	86	1359	1336						

From 1965 ASHRAE GUIDE and DATA BOOK and published data of E. I. duPont de Nemours & Co., Inc. Used by permission. *Inches of mercury below one standard atmosphere

TABLE 5

REFRIGERANT 114 (DICHLOROTETRAFLUOROETHANE)—PROPERTIES OF LIQUID AND SATURATED VAPOR

Temp F	Pressure		Volume cu ft/lb	Density lb/cu ft	Enthalpy** Btu/lb		Entropy** Btu/(lb) (°R)		Temp F	Pressure		Volume cu ft/lb	Density lb/cu ft	Enthalpy** Btu/lb		Entropy** Btu/(lb) (°R)	
	psia	psig			Liquid 1/v _l	Liquid h _l	Vapor h _g	Liquid s _l		Vapor s _g	psia			psig	Vapor v _g	Liquid 1/v _l	Liquid h _l
			Vapor v _g	Liquid 1/v _l								Liquid h _l	Vapor h _g				
-80	0.404	28.97*	81.26	105.603	-8.73	60.44	-0.0227	0.1695	30	12.25	4.99*	2.429	95.73	15.97	75.73	0.0582	0.1572
-78	0.835	28.85*	44.87	105.193	-7.87	60.98	-0.0203	0.1692	32	12.81	3.85*	2.330	95.53	16.48	76.01	0.0581	0.1573
-72	0.62	28.66*	38.92	104.924	-7.01	61.52	-0.0179	0.1689	34	13.38	2.60*	2.236	95.33	16.99	76.29	0.0579	0.1574
-68	0.72	28.46*	34.20	104.624	-6.14	62.06	-0.0155	0.1686	36	13.96	1.47*	2.147	95.13	17.50	76.58	0.0578	0.1575
-64	0.833	28.22*	29.77	104.292	-5.28	62.60	-0.0132	0.1683	38	14.59	0.22*	2.062	94.93	18.02	76.88	0.0577	0.1576
									40	15.22	0.52	1.982	94.73	18.54	77.14	0.0576	0.1577
-60	0.959	27.99*	26.08	103.960	-4.40	63.16	-0.0110	0.1680	42	15.88	1.18	1.905	94.52	19.05	77.42	0.0575	0.1577
-58	1.028	27.83*	24.55	103.792	-3.98	63.43	-0.0098	0.1679	44	16.56	1.88	1.832	94.32	19.56	77.70	0.0574	0.1578
-56	1.10	27.66*	22.94	103.622	-3.82	63.70	-0.0087	0.1678	46	17.26	2.58	1.762	94.12	20.08	77.99	0.0573	0.1579
-54	1.175	27.52*	21.50	103.452	-3.08	63.97	-0.0075	0.1677	48	17.98	3.28	1.695	93.91	20.61	78.27	0.0572	0.1580
-52	1.26	27.35*	20.16	103.282	-2.64	64.25	-0.0064	0.1676									
-50	1.349	27.20*	18.96	103.113	-2.20	64.53	-0.0054	0.1675	50	18.73	4.03	1.632	93.71	20.61	78.55	0.0571	0.1581
-48	1.438	27.0*	17.85	102.938	-1.78	64.80	-0.0043	0.1674	52	19.50	4.80	1.571	93.50	21.08	78.83	0.0570	0.1582
-46	1.535	26.8**	16.80	102.768	-1.32	65.07	-0.0032	0.1673	54	20.29	5.58	1.513	93.30	21.54	79.11	0.0569	0.1583
-44	1.635	26.6*	15.78	102.594	-0.88	65.35	-0.0021	0.1672	56	21.11	6.41	1.458	93.09	22.01	79.39	0.0568	0.1584
-42	1.745	26.4*	14.87	102.422	-0.44	65.63	-0.0010	0.1671	58	21.96	7.28	1.405	92.88	22.48	79.67	0.0567	0.1585
									60	22.83	8.13	1.354	92.68	22.95	79.95	0.0566	0.1587
-40	1.868	26.12*	14.02	102.25	0.00	65.91	0.0000	0.1671	62	23.73	9.02	1.306	92.47	23.42	80.23	0.0565	0.1588
-38	1.990	25.87*	13.20	102.08	0.45	66.19	0.0011	0.1670	64	24.64	9.94	1.260	92.26	23.89	80.51	0.0564	0.1589
-36	2.121	25.60*	12.44	101.90	0.91	66.47	0.0021	0.1669	66	25.56	10.89	1.216	92.05	24.36	80.79	0.0563	0.1590
-34	2.259	25.32*	11.73	101.73	1.36	66.74	0.0032	0.1668	68	26.57	11.87	1.174	91.84	24.83	81.07	0.0562	0.1591
-32	2.404	25.03**	11.07	101.55	1.81	67.02	0.0042	0.1667									
-30	2.537	24.72**	10.45	101.37	2.27	67.30	0.0053	0.1667	70	27.57	12.87	1.133	91.63	25.30	81.35	0.0561	0.1593
-28	2.718	24.39**	9.877	101.19	2.72	67.58	0.0063	0.1667	72	28.61	13.91	1.094	91.41	25.78	81.62	0.0560	0.1594
-26	2.887	24.04**	9.338	101.01	3.17	67.86	0.0074	0.1666	74	29.67	14.97	1.057	91.20	26.25	81.90	0.0559	0.1595
-24	3.064	23.68**	8.833	100.83	3.63	68.14	0.0084	0.1665	76	30.76	16.08	1.021	90.99	26.73	82.18	0.0558	0.1596
-22	3.249	23.31**	8.363	100.65	4.08	68.42	0.0095	0.1665	78	31.84	17.18	0.986	90.77	27.20	82.46	0.0557	0.1597
									80	32.94	18.34	0.951	90.56	27.68	82.73	0.0556	0.1599
-20	3.444	22.91**	7.921	100.47	4.54	68.70	0.0105	0.1665	82	34.22	19.52	0.926	90.34	28.15	83.01	0.0555	0.1600
-18	3.648	22.49**	7.508	100.29	4.99	68.98	0.0116	0.1665	84	35.44	20.74	0.902	90.13	28.63	83.29	0.0554	0.1601
-16	3.862	22.06**	7.121	100.11	5.44	69.26	0.0126	0.1664	86	36.69	21.99	0.878	89.91	29.11	83.56	0.0553	0.1603
-14	4.085	21.61**	6.757	99.92	5.90	69.54	0.0136	0.1664	88	37.97	23.27	0.853	89.69	29.59	83.84	0.0552	0.1604
-12	4.319	21.13**	6.416	99.74	6.35	69.82	0.0146	0.1664									
-10	4.564	20.63**	6.095	99.56	6.81	70.10	0.0157	0.1664	90	39.29	24.59	0.828	89.47	30.08	84.11	0.0551	0.1606
-8	4.819	20.11**	5.794	99.37	7.26	70.38	0.0167	0.1664	92	40.64	25.94	0.803	89.25	30.54	84.39	0.0550	0.1607
-6	5.086	19.57**	5.510	99.19	7.72	70.66	0.0177	0.1664	94	42.02	27.32	0.778	89.03	31.02	84.66	0.0549	0.1608
-4	5.365	19.00**	5.244	99.00	8.18	70.94	0.0187	0.1664	96	43.44	28.74	0.754	88.81	31.50	84.93	0.0548	0.1609
-2	5.655	18.41**	4.992	98.81	8.63	71.22	0.0197	0.1665	98	44.89	30.19	0.731	88.59	31.99	85.21	0.0547	0.1611
0	5.958	17.79**	4.756	98.62	9.00	71.50	0.0207	0.1665	100	46.39	31.69	0.709	88.37	32.47	85.48	0.0546	0.1612
2	6.274	17.15**	4.533	98.44	9.54	71.78	0.0217	0.1665	102	47.92	33.22	0.687	88.15	32.95	85.75	0.0545	0.1614
4	6.603	16.48**	4.322	98.25	10.09	72.07	0.0227	0.1665	104	49.44	34.78	0.667	87.93	33.43	86.02	0.0544	0.1615
5†	6.772	16.14**	4.231	98.15	10.23	72.21	0.0232	0.1665	108	51.09	36.39	0.6274	87.70	34.02	86.29	0.0543	0.1617
6	6.945	15.78**	4.123	98.08	10.48	72.35	0.0236	0.1666									
8	7.391	15.08**	3.935	97.87	10.91	72.63	0.0246	0.1666	110	54.41	39.71	0.5901	87.25	34.89	86.83	0.0542	0.1619
10	7.671	14.31**	3.788	97.68	11.37	72.91	0.0256	0.1666	112	56.14	41.44	0.5724	87.01	35.38	87.09	0.0541	0.1621
12	8.057	13.53**	3.659	97.48	11.83	73.19	0.0266	0.1667	114	57.90	43.20	0.5554	86.77	35.87	87.36	0.0540	0.1622
14	8.457	12.71**	3.531	97.29	12.29	73.47	0.0274	0.1667	116	59.70	45.00	0.5389	86.54	36.33	87.63	0.0539	0.1624
16	8.873	11.86**	3.282	97.10	12.73	73.75	0.0283	0.1668	118	61.55	46.85	0.5230	86.31	36.84	87.89	0.0538	0.1625
18	9.305	10.98**	3.140	96.90	13.20	74.04	0.0293	0.1668	120	63.44	48.74	0.5077	86.08	37.33	88.16	0.0537	0.1627
									124	67.35	52.65	0.4787	85.61	38.32	88.69	0.0536	0.1630
20	9.753	10.07**	3.015	96.71	13.65	74.32	0.0304	0.1669	128	71.43	56.73	0.4515	85.13	39.31	89.21	0.0535	0.1633
22	10.22	9.12**	2.877	96.51	14.12	74.60	0.0314	0.1669	132	75.69	60.99	0.4262	84.65	40.30	89.73	0.0534	0.1635
24	10.70	8.14**	2.756	96.32	14.58	74.88	0.0323	0.1670	136	80.15	65.45	0.4025	84.16	41.29	90.25	0.0533	0.1638
26	11.20	7.12**	2.641	96.12	15.03	75.17	0.0331	0.1671	140	84.79	70.09	0.3803	83.66	42.29	90.76	0.0532	0.1641

From 1965 ASHRAE GUIDE and DATA BOOK and published data of E. I. duPont de Nemours & Co., Inc. Used by permission *Inches of mercury below one standard atmosphere

TABLE 6
PRESSURE CONVERSION TABLE

↑ Above Atmospheric Press.
 Atmos. Press.
 ↓ Below Atmospheric Press.

PSI Abs.	PSI Gage	ATMOS Gage	ATMOS Abs.	Inches of Hg Abs.	Inches of Hg Gage	Inches of Hg Vac.	MM of Hg Abs.	Ft. of Water Abs.	Inches of Water Abs.
191.1	176.4	12	13	388.96	359.04		9880	441.22	5294.6
176.4	161.7	11	12	359.04	329.12		9120		
161.7	147.0	10	11	329.12	299.20		8360		
147.0	132.3	9	10	299.20	269.28		7600		
132.3	117.6	8	9	269.28	239.36		6840		
117.6	102.9	7	8	239.36	209.44		6080		
102.9	88.2	6	7	209.44	179.52		5320		
88.2	73.5	5	6	179.52	149.60		4560		
73.5	58.8	4	5	149.60	119.68		3800		
58.8	44.1	3	4	119.68	89.76		3040		
44.1	29.4	2	3	89.76	59.84		2280		
29.4	14.7	1	2	59.84	29.92		1520		
14.7	0	0	1	29.92	0	0	760	33.94	407.28
13	-1			27.88	-2.036	-2.036	708.3	31.63	378.19
12	-2			25.84	-4.072	-4.072	656.6	29.32	350.58
11	-3			23.81	-6.108	-6.108	604.9	27.01	322.97
10	-4			21.77	-8.144	-8.144	553.2	24.70	295.36
9	-5			19.74	-10.180	-10.180	501.5	22.39	267.75
8	-6			17.70	-12.216	-12.216	449.8	20.08	240.14
7	-7			15.67	-14.252	-14.252	398.1	17.77	212.53
6	-8			13.63	-16.288	-16.288	346.4	15.46	184.92
5	-9			11.60	-18.324	-18.324	294.7	13.15	157.31
4	-10			9.56	-20.360	-20.360	243.0	10.85	129.70
3	-11			7.52	-22.396	-22.396	191.3	8.54	102.09
2	-12			5.49	-24.432	-24.432	139.6	6.23	74.48
1	-13			3.45	-26.468	-26.468	87.9	3.92	46.87
0	-14.7	-1	0	0	-29.92	-29.92	0	0	0

Answers To Practice Exercises

CHAPTER 1

1. A generator produces dynamic electricity. (1-4)
2. Voltage is electrical pressure; current is the movement of electrons and resistance is the opposition to current flow. (1-6, 10)
3. These alloys make it possible to operate at high temperatures without melting. (1-11)
4. The cross-sectional area, the length, and the temperature. (1-12)
5. Hardened iron. (1-16)
6. Number of poles and speed of rotation. (2-10)
7. 2 amperes. (3-4)
8. 240 volt. (3-5)
9. 22 ohms. (3-6)
10. One horsepower. (3-25, 27)
11. The symbol for inductance is L. (4-8)
12. The capacitor gives the motor more torque by causing the current to lead the voltage. (4-10; Fig. 17)
13. Only when the circuit is made up of pure resistance. (4-12)
14. No, only on pulsating dc. (5-61)
15. Iron core, primary winding, and secondary winding. (5-2)
16. Wye-wye, delta-delta, and wye-delta. (5-21)
17. To limit the amount of current flow through the meter circuit. (6-3)
18. The shunt is connected in parallel with the ohmmeter circuit to bypass most of the current around the meter coil circuit. (6-4)
19. Maximum current will flow through the ohmmeter circuit when there is minimum resistance to flow. (6-7)
20. A rectifier must be added to change ac to dc. (6-9)
21. To measure the true power in an ac circuit regardless of the type load. (6-10)
22. To check for a blown fuse the voltmeter is connected in parallel with the fuse. (6-20)
23. To check for continuity in a parallel circuit the unit being tested must be isolated from the rest of the circuit. (6-30)

24. The speed of an ac motor depends on the number of poles and the frequency of the applied electrical source. (7-2)
25. A single-phase induction motor must have two windings, a start and a run winding. (7-5)
26. The motor would run hot and burn out the start winding if allowed to run any length of time. (7-15)
27. A capacitor start, capacitor run. (7-18)
28. A three-phase motor exerts a torque when at rest, and therefore it starts itself when the correct voltage is applied to the stator field coils. (7-23)
29. The reluctance motor operates at exactly synchronous speed because of the salient poles. (7-26)
30. Universal type motor may be used on ac or dc. (7-28)
31. A motor should be lubricated according to applicable publications. (8-3)
32. Circuit protective devices are used to protect the unit and wires in the circuit. (9-7)
33. Two. (9-11)
34. If the fan circuit is not closed, the air conditioner holding oil circuit will be opened at the auxiliary contacts in the fan motor starter. (9-12)
35. Most troubles will be found in the load contacts, holding coil, or heaters. (9-14)

CHAPTER 2

1. Intake, compression, ignition, power, and exhaust. (10-1)
2. The engine oil should be checked when the engine is stopped and the oil is at normal operating temperature. (11-4)
3. An air-fuel ratio of 15 to 1 gives maximum economy. (12-4)
4. Pulsating dc. (13-4)
5. The purpose of the capacitor (condenser) in the engine ignition circuit is to help collapse the magnetic field and to reduce arcing at the points. (13-5)
6. Lead and acid. (13-9)
7. Ethylene glycol should be used when the water-cooled engine will be exposed to freezing temperatures. (14-4)
8. With a 10-pound pressure at a point halfway between the compressor pulley and the drive pulley the belt should deflect 1/2 to 3/4 inch if the belt is correctly adjusted. (15-3)

CHAPTER 3

1. All molecular movement will cease at absolute zero. (16-2)

2. Sublimation. (16-3)
3. Cold is not produced but is merely a result of removing heat. (16-3)
4. Sensible heat is the amount of heat that can be added to or subtracted from a substance without changing its state. (16-4)
5. Latent heat is hidden heat and is the heat that is added to or subtracted from a substance when it changes its state. (16-5)
6. The specific heat of water is 1. (16-7)
7. -40° centigrade is equal to -40° Fahrenheit. (16-16)
8. The relative weight of liquids and solids is determined by specific gravity. (16-18)
9. 2117 pounds per square foot. (16-20)
10. 66,000 foot-pounds; 2 horsepower. (16-23, 24)
11. 778 foot-pounds = 1 Btu. (16-25)
12. 100 Btus. (16-26)
13. The critical temperature. (16-28)

CHAPTER 4

1. The critical temperature of water is 689° F. (18-2)
2. If the critical pressure is not above the condensing temperature the gas will not condense. (18-3)
3. The most desirable refrigerant would have a high latent heat of vaporization. (18-6)
4. Ammonia gives off a white smoke in the presence of a flaming sulphur candle. (18-11)
5. A refrigerant cylinder must never be filled more than 85 percent. (18-17, 18)
6. Boric acid solution may be used if liquid refrigerant comes in contact with the eyes. (18-19)